



# Test Equipment

Dwyer Instruments, Inc. offers instrumentation for calibration, test, or measurement of many process variables such as pressure, temperature, flow, level, pH, conductivity and speed. We've expanded our product line to include pressure, temperature, voltage and current calibrators; pH, TDS, and conductivity testers; tachometers, and multi-meters.

## pH Measurement

pH measurement is used for environmental monitoring, waste water testing, pools and spas, food and beverage, biological sample testing, soil testing, pharmaceutical and industrial processes. The degree of acidity or alkalinity of a solution can be determined by the pH value. pH is defined as the negative logarithm of hydrogen-ion activity. The concentration of hydrogen ions (H+) in a solution relates to the pH value. pH is measured on a scale of 0 to 14 with 7pH being neutral, <7pH indicating acidity and >7pH indicating alkalinity. Higher concentrations of H+ indicates a more acidic solution and a lower pH value.

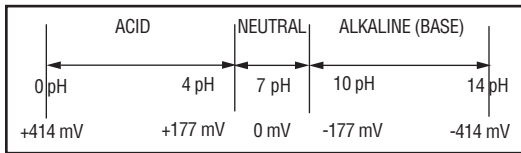

A pH measuring system includes a measuring electrode, reference electrode, and meter. The Dwyer pH testers are designed with a combination electrode which contains a measuring and reference electrode in the same body. The measuring electrode is constructed of nonconductive glass with a pH sensitive glass bulb at the end and a AgCl (silver chloride) wire in the center. The wire is surrounded by KCl (potassium chloride) electrolyte solution. The reference electrode has a AgCl (silver chloride) wire surrounded by an electrolyte solution of KCl saturated with AgCl. A porous liquid junction in the reference electrode allows electrolyte to flow through it and make physical and electrical contact with the solution being measured. This creates an ionic charge on the measuring electrode. A positive charge indicates the solution is acidic and results in a pH value of <7pH. A negative charge indicates the solution is alkaline and results in a value >7pH.

## TDS and Conductivity Measurement

Conductivity is an important measurement in determining water quality such as hardness or purity of water. Applications include boiler water testing, waste water treatment, environmental monitoring, cooling tower feed waters, and leak detection. Conductivity measures a solutions ability to conduct an electric current. The common unit of measure for conductivity is the siemens (S), formerly called the mho (1 micromho [µmho] equals 1 microSiemens [µS]). Conductance is equal to the reciprocal of resistance measured in ohms.

To measure conductivity, two conductive plates (collectively referred to as a conductivity cell) are submersed in a solution with a potential applied across the plates. The resulting current is measured and converted to a conductivity measurement taking into account the cell geometry (the area of each plate and the distance between them).

Conductivity can also be used to indicate the amount of total dissolved solids (TDS) in a solution. Dissolved gases, minerals, and salts contribute to the conductivity of a solution by increasing ion concentration. TDS measurement does not identify the specific dissolved solid but gives an indication of total ion concentration. Dissolved solids measurement is not absolute. Calibration for a specific type of dissolved solids solution is not transferable to another type of dissolved solids solution. A standard calibration solution containing the same type of salts or mixture of salts as the sample solution must be used for calibration.

## Cleaning a Conductivity/TDS Tester

Many applications will only require hot water and a mild detergent to clean the conductivity cell. Use acetone for cleaning if measuring organic materials. Rinse with deionized or distilled water after cleaning and recalibrate the tester. If inaccurate readings are observed, the cell may be polarized and require replatinization.

## Table of Contents

Series MC Multi-Cal Pressure Calibrator	.394
Model MC6 Multi-Cal Benchtop Calibrator	.395
Model HP Hand Pump	.396
Model A-396A Calibration Pump	.396
Model PHP Pneumatic Hand Pump	.397
Model HHP Hydraulic Hand Pump	.397
Model UPT1000 Digital Hand-Held Universal T/C - Process Indicator	.398
Model CA10 Thermocouple Calibrator	.399
Model CA20 Thermocouple Calibrator	.399
Model CAL30 Process Calibrator	.400
Model LC21 Smart Loop Calibrator	.400
Model ASG Analog Signal Generator	.401
Model MM10 Digital Multimeter	.401
Series TAC Pocket Tachometer	.402
Model A-800 Proximity Switch Tester	.402
Model WPH2 Pocket Sized pH Tester	.403
Model WPH1 Waterproof Pocket Sized pH Tester	.403
Series TDS Total Dissolved Solids (TDS) Tester	.404
Series EC Conductivity Tester	.404
Model M Safe-T-Ohm® Shoe Tester	.405
Model TR-7 Safe-T-Ground	.405
Series DT Detector™ Position Sensor	.406
Series PS Proximity Sensors	.406
Model SSR-15 Intrinsic Safe Relay	.407
Series SSR Solid State Relay	.407
Series CT40/50 Current Transformer	.408
Series CT60/70 True RMS Current Transformer	.408
Series CS Current Switches	.409
Model FC-1000 Electronic Fan Speed Control	.409
Related Products and Accessories	.410-411



ITM  
Muhendislik San. ve Tic. A.S.  
I. Karaoğlanolu Etem Zengin Is Merkezi No: 25  
34418 Seyrantepe - Istanbul - Turkiye  
Tel: +90 212 278 78 12 Fax: +90 212 278 78 11  
web site: www.itmfilter.com e-mail: itm@tahas.com

## Calibrators/Testers/Sensors pgs 394 - 406



Test Equipment



Series  
MC

# Multi-Cal Pressure Calibrator



Interchangeable Ranges,  $\pm 0.05\%$  Accuracy, Datalogging Capability, NIST Traceable

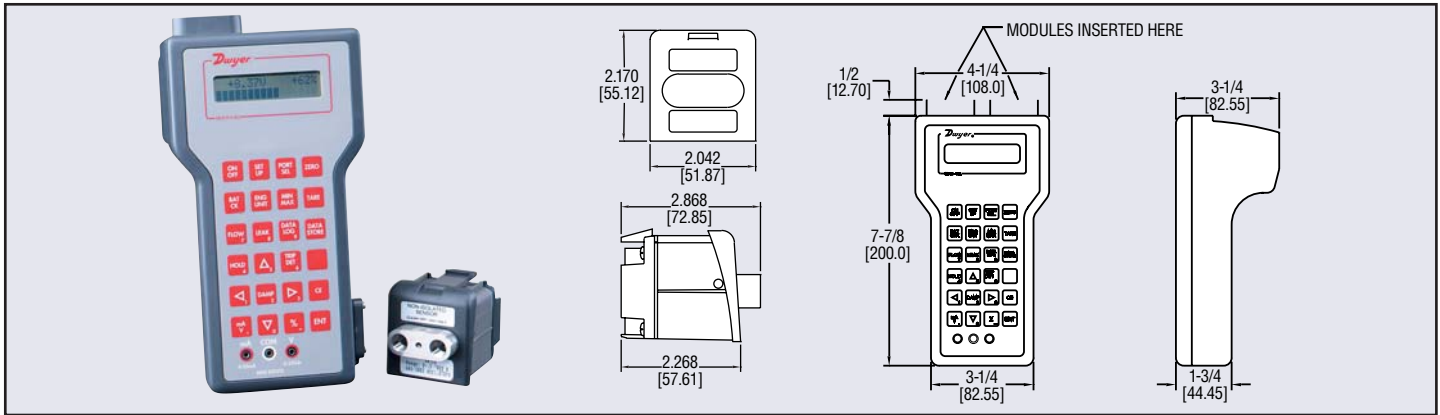

**Series MC Portable Multi-Cal Pressure Calibrator** performs a wide variety of simple and complex pressure based measurement, test, and calibration operations. Modular sensor design allows user to select pressure measurement range for application flexibility. Calibrator can accommodate up to two interchangeable pressure modules (sold separately below) in any combination of range or accuracy.

Simultaneously display two separate measurements on the two line, alphanumeric display. Readings can be displayed in a choice of 12 pre-programmed engineering units or any single user-defined unit. Calibrator features min/max recall, hi/lo alarm, percentage of full scale pressure readings, mA/voltage measurement, leak rate and pressure decay measurement, switch testing capabilities, including trip point and dead band, and velocity/volume flow rates.

Quickly document calibration procedures using the data logging feature which stores up to 384 sets of pressure and time/date stamped measurements. Easily upload stored data to an IBM compatible computer via the RS232 port. Calibrators and modules include certification to NIST traceability—ideal as a secondary standard for calibrating pressure equipment.

Multi-Cal Pressure Calibrator includes utility software, test leads, protection module, adjustable hand strap, AC adapter, two 9V batteries, instruction manual, and hard carrying case.

**Model Number MC2K** Handheld Calibrator  
**Model Number CP40** Serial Printer

**Multi-Cal Pressure Modules** are interchangeable and available in a wide selection of pressure ranges and accuracies. Handheld calibrator accepts up to two pressure modules. Modules include NIST calibration certification.

## MODELS

MODEL NUMBER	RANGE
MC1000	0.25" H <sub>2</sub> O Differential Pressure, $\pm 0.07$
MC1001	0.50" H <sub>2</sub> O Differential Pressure, $\pm 0.07$
MC1004	5.00" H <sub>2</sub> O Differential Pressure, $\pm 0.06$
MC1006	25" H <sub>2</sub> O Differential Pressure, $\pm 0.06$
MC2010	5.0 psig Gauge Pressure, $\pm 0.05$
MC2012	15.0 psig Gauge Pressure, $\pm 0.05$
MC2016	100.0 psig Gauge Pressure, $\pm 0.05$

**Options**—Consult factory for other pressure ranges and accuracies. FM approved models are also available.

## SPECIFICATIONS

**Service:** Clean, dry, nonconductive, noncorrosive gases.

**Accuracy:** Differential Pressure Modules:  $\pm 0.06\%$  FS, Gauge Pressure Modules:  $\pm 0.05\%$  FS, Voltage Input:  $\pm 0.025\%$  FS @ 0/10 VDC,  $\pm 0.10\%$  FS @ 0/30 VDC, Current Input:  $\pm 0.03\%$  FS @ 0/20 mA,  $\pm 0.05\%$  FS @ 0/50 mA.

**Sensitivity:**  $\pm 0.002\%$  of span with dampening 1 part in 50,000 (max).

**Repeatability:** Ranges A0/2 psi:  $\pm 0.05\%$  of span, Ranges B0/5 psi:  $\pm 0.02\%$  of span.

**Output:** RS232 serial interface, 9-pin.

**Alarm Output:** SPST form C 110 VDC, 120 VDC (max.), 1 A (max), 30 W, 62.5 VA (resistive).

**Display:** Alphanumeric LCD, 0.37" (9.5 mm) height per line, 2 lines, 16 characters/line.

**Display Update:** 100 msec.

**Ambient Operating Temperature:** 32 to 120°F (0 to 49°C).

**Storage Temperature:** -4 to 158°F (-20 to 70°C).

**Process Connection:** 1/8" female NPT.

**Electrical Connections:** Miniature recessed banana jacks.

**Power Requirements:** Internal: two 9 VDC alkaline batteries, External: AC adapter 9 VDC, 500 mA.

**Battery Life:** 30 hours (approximate).

**Engineering Units:** inH<sub>2</sub>O, psi, inHg, kPa, mbar, cmH<sub>2</sub>O, mmHg, and user-defined.

**Overpressure:** Differential Pressure Modules: 50 psi positive direction, 15 psi negative direction, Gauge Pressure Modules: 2x range (0/5 psi to 0/1000 psi).

**Temperature Compensation:** 20 to 120°F (-7 to 49°C).

**Temperature Error:** Maximum of  $\pm 0.004\%$  of span per °F over compensated range for zero and span.

**Temperature Effect Electrical Measurement:**  $\pm 0.001\%$  of span per °F over compensated range.

**Dampening:** (Measurement averaging) programmable from 0 to 16 consecutive readings.

**Baud Rate:** 300, 1200, 2400, or 9600, selectable.

**Housing Material:** ABS plastic.

**Weight:** Calibrator: 2.2 lb (1.3 kg), Pressure Module: 0.5 lb (0.3 kg).

**Agency Approvals:** CE.

## APPLICATIONS

Pressure measurement for clean room control, filter performance monitoring, HVAC testing and setup, draft measurement, airflow measurement control, differential pressure measurement in laminar flowhoods, paint booths, industrial ovens and fume hoods. Use as a secondary standard for calibrating pressure equipment.

Test  
Equipment



Model  
MC6

# Multi-Cal Benchtop Calibrator



Interchangeable Ranges,  $\pm 0.05\%$  Accuracy, Datalogging Capability, NIST Traceable

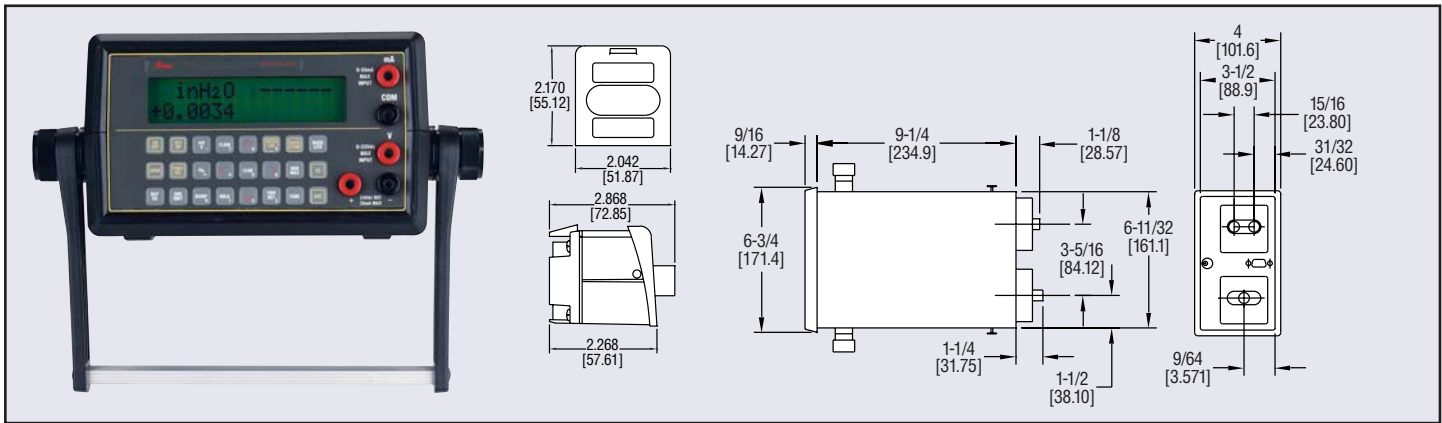

**Model MC6 Multi-Cal Benchtop Calibrator** performs a wide variety of simple and complex pressure based measurement, test, and calibration operations. Modular sensor design allows user to select pressure measurement range for application flexibility. Calibrator can accommodate up to two interchangeable pressure modules (sold separately below) in any combination of range or accuracy.

Simultaneously display two separate measurements on the two line, alphanumeric display. Readings can be displayed in a choice of twelve preprogrammed engineering units or any single user-defined unit. Calibrator features min/max recall, hi/lo alarm, percentage of full scale pressure readings, mA/voltage measurement, leak rate and pressure decay measurement, switch testing capabilities, including trip point and dead band, and velocity/volume flow rates.

Quickly document calibration procedures using the data logging feature which stores up to 384 sets of pressure and time/date stamped measurements. The automatic % error calculation simplifies transmitter calibration. Easily upload stored data to an IBM compatible computer via the RS232 two-way communications port. Calibrators and modules include certification to NIST traceability—ideal as a secondary standard for calibrating pressure equipment.

Multi-Cal Pressure Calibrator includes utility software, protection module, adjustable handle, AC adapter, and instruction manual.

**Model No. MC6** Benchtop Calibrator

**Multi-Cal Pressure Modules** are interchangeable and available in a wide selection of pressure ranges and accuracies. Benchtop calibrator accepts up to two pressure modules. Modules include NIST calibration certification.

## MODELS

Model Number	Range
MC1000	0.25" H <sub>2</sub> O Differential Pressure, $\pm 0.07$
MC1001	0.50" H <sub>2</sub> O Differential Pressure, $\pm 0.07$
MC1004	5.00" H <sub>2</sub> O Differential Pressure, $\pm 0.06$
MC1006	25" H <sub>2</sub> O Differential Pressure, $\pm 0.06$
MC2010	5.0 psig Gauge Pressure, $\pm 0.05$
MC2012	15.0 psig Gauge Pressure, $\pm 0.05$
MC2016	100.0 psig Gauge Pressure, $\pm 0.05$

Options-Consult factory for other pressure ranges and accuracies.

## SPECIFICATIONS

**Service:** Clean, dry, nonconductive, noncorrosive gases.

**Accuracy:** Differential Pressure Modules:  $\pm 0.06\%$  FS, Gauge Pressure Modules:  $\pm 0.05\%$  FS, Voltage Input:  $\pm 0.025\%$  FS @ 0/10 VDC,  $\pm 0.10\%$  FS @ 0/30 VDC, Current Input:  $\pm 0.03\%$  FS @ 0/20 mA,  $\pm 0.05\%$  FS @ 0/50 mA.

**Sensitivity:**  $\pm 0.002\%$  of span with dampening 1 part in 50,000 (max).

**Repeatability:** Ranges A0/2 psi:  $\pm 0.05\%$  of span, Ranges B0/5 psi:  $\pm 0.02\%$  of span.

**Output:** RS232 serial interface, 9-pin.

**Alarm Output:** SPST form C 110 VDC, 120 VDC (max.), 1 A (max), 30 W, 62.5 VA (resistive).

**Display:** Alphanumeric LCD, 0.37" (9.5 mm) height per line, 2 lines, 16 characters/line.

**Display Update:** 100 msec.

**Ambient Operating Temperature:** 32 to 120°F (0 to 49°C).

**Storage Temperature:** -4 to 158°F (-20 to 70°C).

**Process Connection:** 1/8" female NPT.

**Electrical Connections:** Standard banana jacks.

**Power Supply:** 110 VAC/60 Hz adapter, 500 mA.

**Engineering Units:** in H<sub>2</sub>O, psi, in Hg, kPa, mbar, bar, cm H<sub>2</sub>O, mm Hg, ftSW, MPa, mmH<sub>2</sub>O, kgcm<sup>2</sup> and user-defined.

**Overpressure:** Differential Pressure Modules: 50 psi positive direction, 15 psi negative direction, Gauge Pressure Modules: 2x range (0/5 psi to 0/1000 psi).

**Temperature Compensation:** 20 to 120°F (-7 to 49°C).

**Temperature Error:** Maximum of  $\pm 0.004\%$  of span per °F over compensated range for zero and span.

**Temperature Effect Electrical Measurement:**  $\pm 0.001\%$  of span per °F over compensated range.

**Dampening:** (Measurement averaging) programmable from 0 to 16 consecutive readings.

**Baud Rate:** 300, 1200, 2400, or 9600, selectable.

**Computer Requirements:** IBM compatible 386 or above and Windows® 3.1 or later with 2mB RAM and 2mB hard drive disk space, one serial port.

**Housing Material:** ABS plastic.

**Weight:** Calibrator: 3.0 lb (1.4 kg), Pressure Module: 0.5 lb (0.3 kg).

**Agency Approvals:** CE.

## APPLICATIONS

Pressure measurement for clean room control, filter performance monitoring, HVAC testing and setup, draft measurement, airflow measurement control, differential pressure measurement in laminar flowhoods, paint booths, industrial ovens and fume hoods. Use as a secondary standard for calibrating pressure equipment.

Test  
Equipment



Model  
HP

# Hand Pump

Generates Pressures up to 30 psi (2 bar), Single Hand Operation

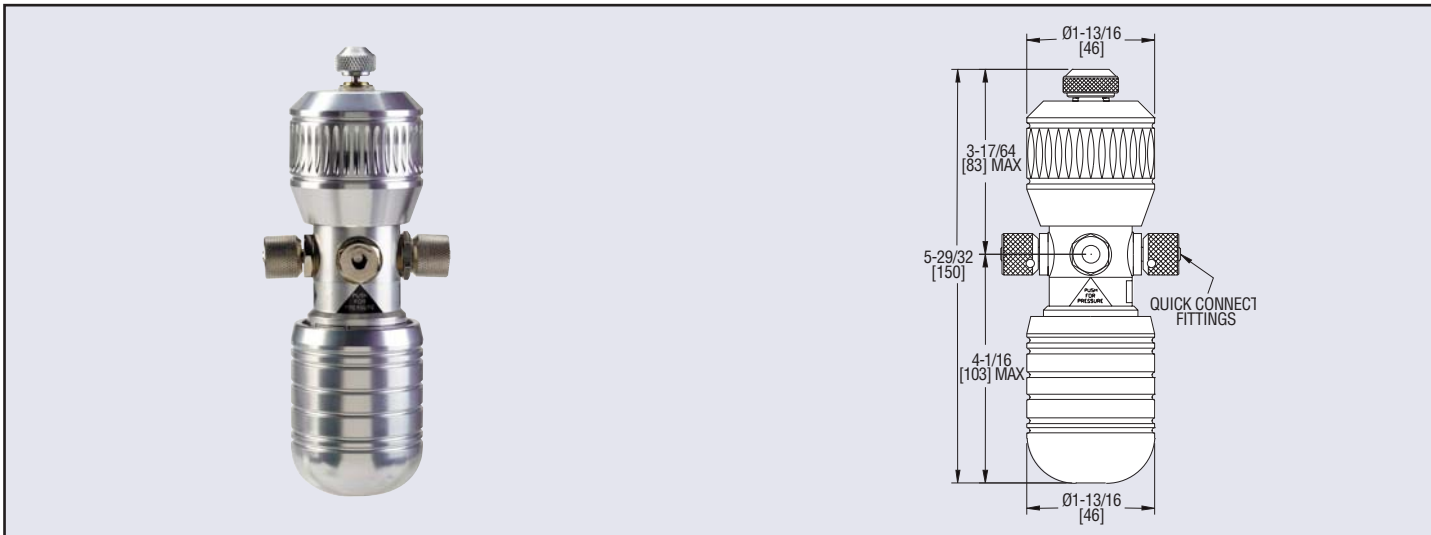

**Model HP Hand Pump** provides a dual source of pneumatic pressure and vacuum for verifying the calibration of pressure instrumentation. Pump can generate pressures up to 30 psi (2 bar) and vacuum to -25" Hg (-850 mbar). The compact pump is designed for portability and single hand operation.

Model HP features a pressure relief valve and fine adjustment for control better than 0.0015 psi (0.1 mbar). Pump includes two 39" (1 m) hoses terminating in 1/4" female NPT connections and instruction manual.

## SPECIFICATIONS

**Output Ranges:** -25" Hg to 30 psi (-850 mbar to 2 bar).

**Process Connection:** 1/4" female NPT (quick fit).

**Fine Adjustment:** Better than 0.0015 psi (0.1 mbar).

**Materials:** Nickel plated brass and anodized aluminum.

**Weight:** 20 oz (587 g).

**Model HP-1** Hand Pump

### ACCESSORIES

Model HP-1K Service Kit  
Model HP-1C Hard Case



Model  
A-396A

# Calibration Pump



**Serves as pressure source** to calibrate gages and transmitters or to set pressure switches. Use with manometer or other pressure standard. Includes volume adjuster enabling fine pressure control and bleed valve. Generates pressures from a fraction of an inch w.c. to 72 psig (5 bar). Includes barbed fitting, tee connector and three 36" lengths of vinyl tubing.

**Model No. A-396A** Calibration Pump . . . . .

Test  
Equipment



Model  
PHP

# Pneumatic Hand Pump

Generates Pressures up to 600 psi (40 bar), Portable

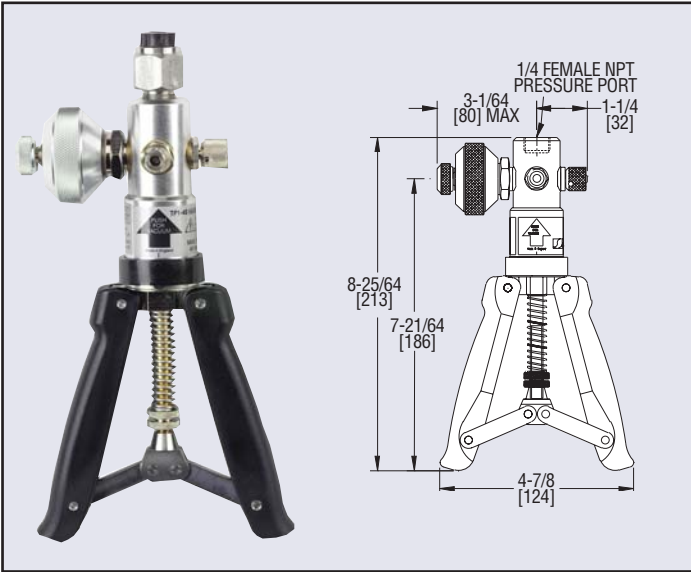

Model PHP-1 Pneumatic Hand Pump

### Accessories

- Model PHP-1K Service Kit
- Model PHP-1C Hard Case

**Verify calibration** of pressure transmitters, switches, controllers, indicators, and recorders with Model PHP Pneumatic Hand Pump. The Model PHP is a hand operated pump for sourcing pressure and vacuum. Use in conjunction with an analog or digital gage for a complete calibration system.

The unit provides output pressures up to 600 psi (40 bar) or vacuum down to -28.5" Hg (-0.960 bar). The reliable pump reaches 100 psi in 4 strokes. Model PHP is fitted with a fine adjustment valve for precise volume control and an adjustable stroke to provide over pressure protection.

Model PHP includes a 39" (1 m) hose with a 1/4" female NPT quick fit connector. The optional service kit includes seals, O-rings, retaining screws and an allen key.

### SPECIFICATIONS

- Output Ranges:** -28.5" Hg to 600 psi (-0.960 to 40 bar).
- Process Connection:** 1/4" female NPT (quick fit).
- Gage Connection:** 1/4" female NPT.
- Materials:** Nickel plated brass, anodized aluminum, and nylon.
- Weight:** 1.4 lb (0.65 kg).



Model  
HHP

# Hydraulic Hand Pump

Pressures up to 10,000 psi (700 bar), Oil or Water

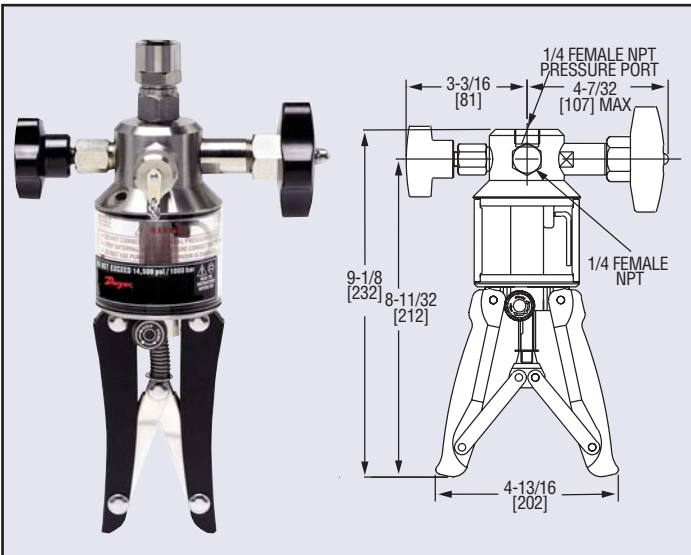

Model HHP-1 Hydraulic Hand Pump

### Accessories

- Model HHP-1K Service Kit
- Model HHP-1C Hard Case
- Model HHP-6K High Pressure Hose Kit

**Generate pressures** up to 10,000 psi (700 bar) with Model HHP-1 Hydraulic Hand Pump. Scissor action pump allows quick priming and pressure generation. Use in conjunction with an analog or digital pressure gage for a complete calibration system.

The pump is designed with a large, see through reservoir with a capacity of over 4 oz. A variety of fill liquids can be used including mineral oil, distilled water, and alcohol. The sealed stainless steel and tempered glass construction provide leak free operation.

Model HHP offers adjustable over pressure protection, fine control, and a unique selector switch to move from priming to high pressure generation.

### SPECIFICATIONS

- Output Ranges:** 0 to 10,000 psi (0 to 700 bar).
- Process Connection:** 1/4" female NPT (quick fit).
- Gage Connection:** 1/4" female NPT.
- Materials:** Stainless Steel and tempered glass.
- Weight:** 3.5 lb (1.6 kg).

Test  
Equipment



Model  
UPT1000

# Digital Hand-Held Universal T/C - Process Indicator

Microprocessor Based, Programmable Resolution



The Love Controls UPT1000 Digital Hand-Held Universal Thermocouple - Process Indicator is a microprocessor based precision-general-purpose thermometer and process indicator designed for use with a multitude of standard inputs. These inputs include Type J, K, T, E, R, S, B, and N Thermocouples as well as 100 ohm 2 or 3-wire Platinum RTDs, 120 ohm Nickel RTDs, and 1000 ohm Platinum 2 wire RTDs. In addition to these temperature inputs the UPT1000 is capable of measuring current inputs (4-20 mA<sub>d.c.</sub>) and voltage inputs (0 - 10 V<sub>d.c.</sub>) making it an ideal instrument for calibrating and validating a variety of process instruments. Love Controls UPT1000 is a class leading handheld indicator offering 0.25% full-scale accuracy over thirteen common input ranges. The unit is packaged in a sturdy extruded aluminum case that will help to ensure years of service and dependability. The UPT1000 is designed and manufactured in the USA and carries a 1-year limited warranty.

Also available are a soft carrying case (L402-A), and a variety of ANSI connectors and handheld temperature probes, offered in both kits or individually.

The UPT1000 is the ideal thermocouple thermometer for use in laboratories, factories, shops, and any location where accurate temperature measurement is required.

**UPT1000** Digital Hand-Held Universal Thermocouple - Process Indicator

**L402-A** Soft Case

See Digital Thermocouple, Thermocouple Kits and Hand Held Thermocouples.

## FEATURES

- Microprocessor Based
- Standard ANSI Mini-jack Connector
- Detachable Screw Terminals
- °F, °C, or Process Variable Descriptors Selectable
- Programmable Resolution
- Peak and Valley Indication
- 20 Minute Auto-Power Off
- Backlit Display
- High Accuracy
- Sturdy Extruded Aluminum Case
- Made in USA

## SPECIFICATIONS

**Selectable Inputs:** Thermocouple, RTD, DC Voltage, or DC current.

**Input Impedance:** Thermocouple = 3 megohms, Current = 10 ohms, Voltage = 5000 ohms.

**RTD Excitation Current:** 200µA.

**Display:** Two 4-1/2 digit LCD.

**Accuracy:** ±0.25% of span; ±1 least significant digit.

**Maximum Overload:** Current = 110 mA, Voltage = 25V<sub>d.c.</sub>

**Resolution:** 1 count, 1 degree or 0.1 degree selectable.

**Drift Over Temperature:** ±0.02% (200 ppm) per °C typical, ±0.05% (500 ppm) maximum.

**Memory Backup:** Non-Volatile EEPROM.

**Response Time:** 2 readings per second.

**Operating Temperature:** 32 to 104°F (0 to 40°C).

**Humidity Conditions:** 0 to 40% Non-Condensing.

**Power:** 9V battery.

**Battery Life:** 200 hours typical.

**Case Material:** Anodized aluminum with plastic end caps.

**Dimensions:** 172.7 x 71 x 22.9 mm (6.8"L x 2.8"W x 0.9"D).

## INPUTS

INPUT TYPE	RANGE °F	RANGE °C
Type J Thermocouple	-100 to +1600	-73 to +871
Type K Thermocouple	-200 to +2500	-129 to +1371
Type T Thermocouple	-350 to +750	-212 to +398
Type E Thermocouple	-100 to +1800	-73 to +982
Type R Thermocouple	0 to 3200	-17 to +1760
Type S Thermocouple	0 to 3200	-17 to +1760
Type B Thermocouple	+75 to +3308	+24 to +1820
Type N Thermocouple	-100 to +2372	-73 to +1300
100 K Plt. 0.00385 DIN RTD	-328 to 1607	-200 to +875
100 K Plt. 0.00392 NIST RTD	-328 to 1607	-200 to +875
120 K Nickel 0.00628 US RTD	-112 to +608	-80 to +320
1000 K Plt. 0.00385 DIN RTD	-328 to +1607	-200 to +875
Current/Voltage Scalable Units from -1999 to +9999.		

Test  
Equipment



Model CA10

# Thermocouple Calibrator

Accepts Type K Thermocouples, High/Low Alarm, Selectable Resolution



**Dual function CA10 Thermocouple Calibrator** can be used to source Type K thermocouple output values or measure Type K thermocouples. Quickly select output value using the rotary switch with coarse and fine adjustments. Model CA10 accepts up to two Type K thermocouples and features data hold and max functions. Measurements are displayed on a 3-1/2 digit backlit display. Units include a 4" (100 m) Type K bead wire temperature probe, calibration cable, 9V battery and instruction manual.

**Model CA10** Thermocouple Calibrator

### SPECIFICATIONS

**Measurement Range:** -40 to 1400°F (-40 to 760°C), selectable.  
**Thermocouple Input:** Type K.  
**Input Protection:** 24 VDC or 24 VAC rms max input voltage on any combination of input pins.  
**Accuracy:** ±0.1% rdg. + 2°F on -40 to 1400°F; ±0.1% rdg. + 1°C on -40 to 760°C, over operating temperature of 64 to 82°F (18 to 28°C).  
**Output Range:** -328 to 2192°F (-210 to 1200°C).  
**Display:** 0.8" (20 mm) height, 3-1/2-digit LCD with switchable back light.  
**Resolution:** Selectable 1° or 0.1°.  
**Reading Rate:** 2.5 times/second.

**Ambient Operating Temperature:** 32 to 122°F (0 to 50°C) max 80% RH.  
**Storage Temperature:** -4 to 140°F (-20 to 60°C) max 70% RH.  
**Thermocouple Connection:** Standard female mini-connector.  
**Power Requirements:** 9V Alkaline (included).  
**Battery Life:** 200 hours typical.  
**Temperature Coefficient:** 0.1 times the applicable accuracy specification per °F from 32 to 64°F and 82 to 122°F (0 to 18°C and 28 to 50°C).  
**Housing Material:** ABS plastic.  
**Weight:** 15.5 oz (440 g).  
**Agency Approvals:** CE.



Model CA20

# Thermocouple Calibrator

Accepts Type J Thermocouples, High/Low Alarm, Selectable Resolution

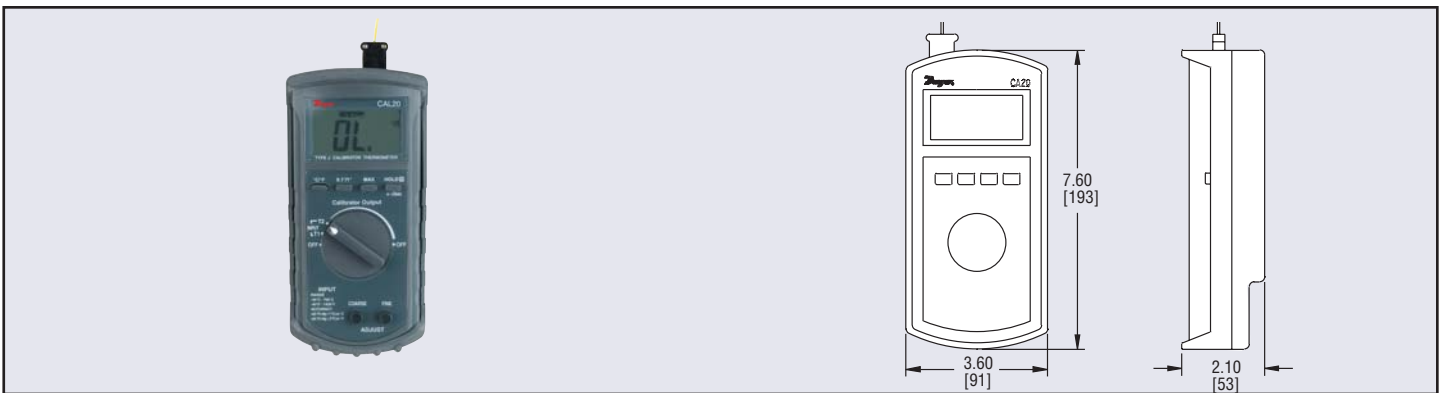

**Dual function CA20 Thermocouple Calibrator** can be used to source Type J thermocouple output values or measure Type J thermocouples. Quickly select output value using the rotary switch with coarse and fine adjustments. Model CA20 accepts up to two Type J thermocouples and features data hold and max functions. Measurements are displayed on a 3 1/2-digit backlit display. Units include a 4" (100 m) Type J bead wire temperature probe, calibration cable, 9V battery and instruction manual.

**Model CA20** Thermocouple Calibrator . . . . .

### SPECIFICATIONS

**Measurement Range:** -40 to 1400°F (-40 to 760°C), selectable.  
**Thermocouple Input:** Type J.  
**Input Protection:** 24 VDC or 24 VAC rms max input voltage on any combination of input pins.  
**Accuracy:** ±0.1% rdg. + 2°F on -40 to 1400°F; ±0.1% rdg. + 1°C on -40 to 760°C, over operating temperature of 64 to 82°F (18 to 28°C).  
**Output Range:** -328 to 2192°F (-210 to 1200°C).  
**Display:** 0.8" (20 mm) height, 3 1/2-digit LCD with switchable back light.  
**Resolution:** Selectable 1° or 0.1°.  
**Reading Rate:** 2.5 times/second.

**Ambient Operating Temperature:** 32 to 122°F (0 to 50°C) max 80% RH.  
**Storage Temperature:** -4 to 140°F (-20 to 60°C) max 70% RH.  
**Thermocouple Connection:** Standard female mini-connector.  
**Power Requirements:** 9V Alkaline (Included).  
**Battery Life:** 200 hours typical.  
**Temperature Coefficient:** 0.1 times the applicable accuracy specification per °F from 32 to 64°F and 82 to 122°F (0 to 18°C and 28 to 50°C).  
**Housing Material:** ABS plastic.  
**Weight:** 15.5 oz (440 g).  
**Agency Approvals:** CE.

Test Equipment



Model  
CAL30

# Process Calibrator

Measures and Generates DC Voltage, mV and Current, Programmable

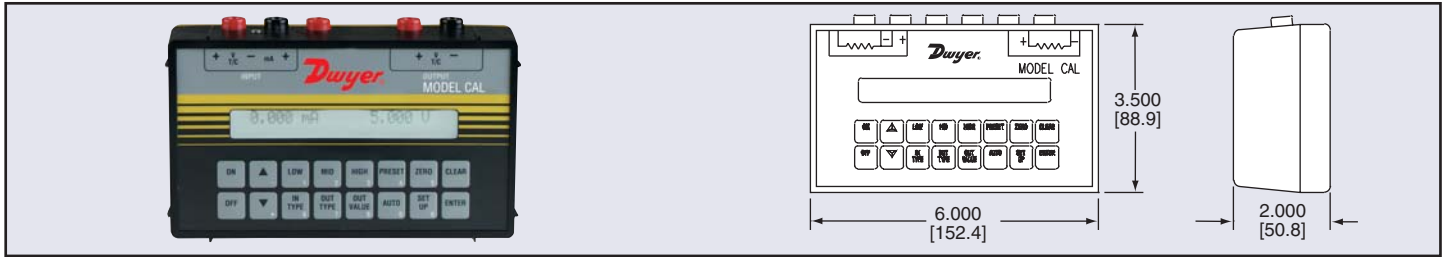

**Calibrate** electronic process instruments such as controllers, transmitters, or recorders with model CAL30 Process Calibrator. Model CAL30 is designed to independently measure and simulate DC volts, mV, and current. These calibrators simulate a two-wire field transmitter and generate a controlled output current when connected to an external power supply. Units source a four-wire transmitter by generating a controlled 4-20 mA DC from an external 25 V power supply.

Programmable functions, such as square root extraction for flow signals, ramp/step increment value, selectable engineering units, isolated signal conversion or automatic changing of the output value simplify many calibration tasks. Calibration values can be stored and recalled using the Low, Mid, or High keys. Program the automatic shut-off to conserve battery life.

The Model CAL30 Calibrator features 500 VDC input/output isolation and reverse polarity protection. The unit includes three 9V batteries, two sets of dual test leads, a dual binding post adapter, carrying case, and instruction manual.

Model CAL30 Process Calibrator

## SPECIFICATIONS

**Input Ranges:** Voltage: -10 to 24 mV DC; -10 to 120 mV DC (autoranging); 0 to 12 VDC; Current: 0 to 24 mA DC.

**Input Impedance:** 1 MK minimum plus 10 nano-Amps maximum for V and mV inputs; 40K for mA DC.

**Accuracy:**  $\pm 0.025\%$  of range.

**Output Ranges:** 0 to 120.0 mV DC (2KK min. load); 0 to 12.0 VDC (2KK min. load); 0 to 24.0 mA DC (25 volts excitation).

**Input/Output Isolation:** 500 VDC.

**Display:** 24-character LCD, 3/16" (5 mm) character height.

**Indication:** Up to 5 digits depending on range.

**Warm-up Time:** 60 seconds, maximum.

**Ambient Operating Temperature:** -4 to 113°F (-20 to 45°C).

**Electrical Connections:** Standard banana jacks on 3/4" (19 mm) centers.

**Power Requirements:** Three 9V alkaline (included).

**Battery Life:** 100 hours, approx.

**Weight:** 1.15 lb (0.52 kg).  
**Agency Approvals:** CE.



Model  
LC21

# Smart Loop Calibrator

Sources and Reads Milliamps, Auto-Stepping, Auto-Ramping

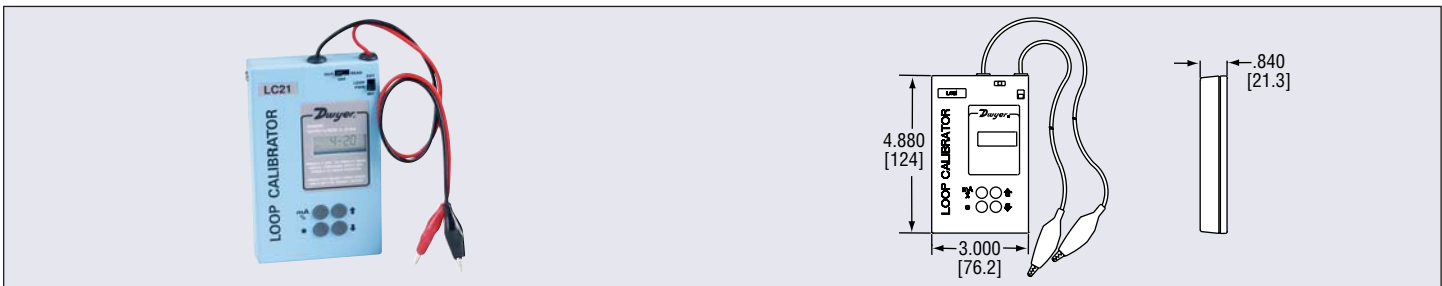

**Perform field calibration** of 2-wire transmitters, receivers, recorders, and controllers with Model LC21 Smart Loop Calibrator. The portable LC21 calibrator sources 24 VDC, reads 0 to 21.00 milliamps and simulates 2-wire transmitters. Unit features continuous output or fixed step current output. Use fixed calibration currents to test and calibrate equipment or to control valve stroking. Output currents can be changed manually or automatically. The LC21 calibrator can source or simulate continuous up/down cycling between 4 and 20 mA or 0 and 20 mA—ideal for endurance testing. Display readings in mA or in % of 4-20 mA or 0-20mA. Unit includes carrying case, batteries, spare fuse, and manual.

Model LC21 Smart Loop Calibrator

## Accessories

No. LC21-110, 110 VAC Adapter  
No. LC21-230, 230 VAC Adapter

## SPECIFICATIONS

**Input Range:** 0 to 21.00 mA.

**Accuracy:**  $\pm 0.05\%$  of range.

**Output Range:** 0 to 21.00 mA.

**Fixed Steps:** Output in mA  
4-20mA lin: 4-8-12-16-20,  
0-20mA lin: 0-5-10-15-20,  
4-20mA sq. rt (flow): 4-5-8-13-20,  
0-20mA sq. rt (flow): 0-1.25-5-11.25-20,  
4-20mA valve: 3.8-4-4.2-12-19-20-21.

**Fixed Step Interval:** 10 seconds in auto-stepping mode.

**Auto-Ramping Interval:** 60 seconds between limits.

**Resolution:** 10 microamps.

**Temperature Effect:** 0.0015% per °F, 0.003% per °C.

**Ambient Operating Temperature:** 14 to 122°F (-10 to 50°C), Storage: -65 to 260°F (-54 to 126°C).

**Electrical Connections:** 13" (33 cm) length.

**Power Requirements:** Four AA 1.5V alkaline batteries.

**Battery Life:** Sources 12 mA: 13 hours; Measures: 64 hours.

**Internal Loop Power:** 24 VDC stabilized.

**External Loop Power:** 56 VDC maximum.

**Drive Capability:** 900K.

**Housing Material:** High impact ABS

**Weight:** 9 oz (285 g).

**Agency Approvals:** CE.



Model  
ASG

# Analog Signal Generator

Ramp Function, Bar Graph LED, Selectable Auto Shut Off

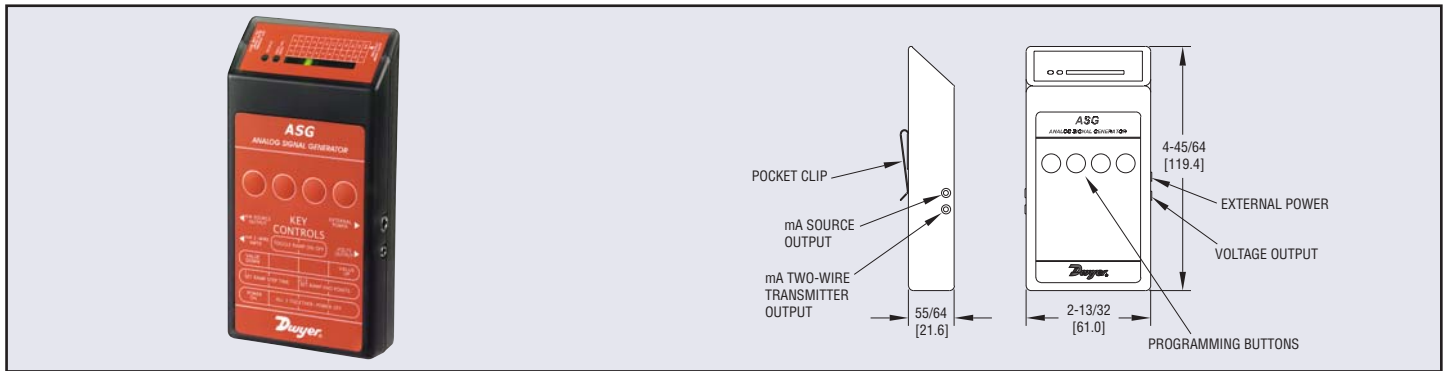

The pocket size model ASG Analog Signal Generator is an ideal tool for troubleshooting transmitters, transducers, motors and actuators. The unit generates a 0 to 10 VDC signal in increments of 1 volt or a 4 to 20 mA signal in increments of 2 mA. An LED bar graph visually indicates analog signal level. The model ASG will also continuously ramp to user defined maximum and minimum values with user defined ramp interval timing. Units are furnished with 6 ft (1.8 m) leads with alligator clips, 120 VAC plug in adapter protective carrying case and instruction manual.

## SPECIFICATIONS

**Impedance:** Voltage: 1000K min. Current: 300K max.  
**Output:** 0 to 20 mA (2 mA increments).  
0-10 VDC (1 VDC increments).  
**Resolution:** 2 mA (current). 1 VDC (voltage).  
**Ramping Time Intervals:** 2 to 20 sec (2 sec increments).  
**Ambient Operating Temperature:** 32 to 122°F (0 to 50°C).  
**Power Requirements:** 9-Volt battery or 120 VAC (provided).  
**Auto Shutoff Times:** 2 to 20 min. (2 min. increments)  
(6 minute default).  
**Electrical Connections:** 6 ft (1.8 m) with alligator clips.  
**Weight:** 3.2 oz (without battery).  
**Agency Approvals:** CE.

Model ASG Analog Signal Generator



Model  
MM10

# Digital Multimeter

Measures DC /AC Voltage, DC Current and Resistance, Overload Protection

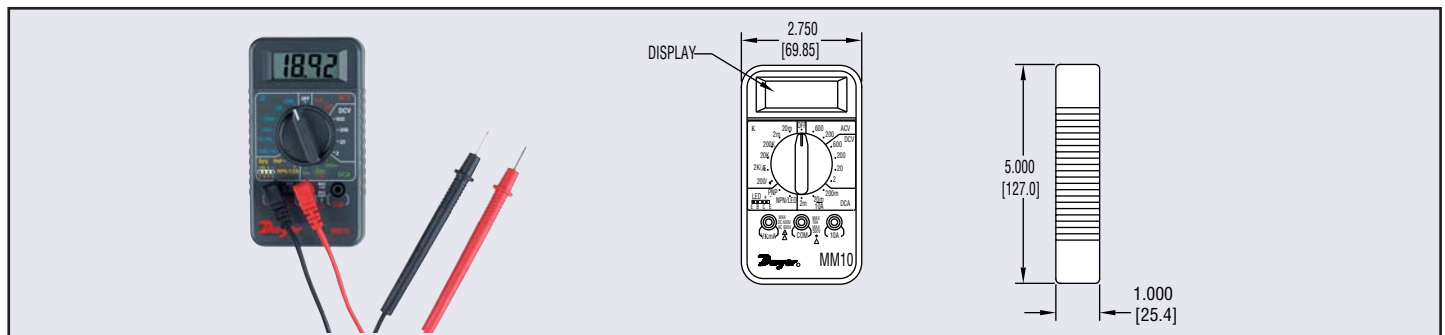

Our compact, low cost Model MM10 Digital Multimeter is ideal for general electrical testing and troubleshooting. This full function multimeter measures DC and AC voltage to 600V, DC current to 10A and resistance to 20MΩ. In addition to volts, amps and ohms, this meter includes audible continuity, diode, LED and transistor hFE tests. The 3-1/2 digit LCD features automatic polarity correction, low battery and overload indication. Rugged, high impact case comes equipped with built-in tilt-stand for versatile, hands-free operation. Overload protected to 600VAC/600VDC for voltage ranges and to 500VAC/500VDC for resistance, diode and continuity test ranges. Current ranges are protected by 0.5A/250V, replaceable fuse. Multimeter is furnished with 22" test leads, 9V battery and instruction manual.

## SPECIFICATIONS

**DC VOLTAGE**  
**Ranges:** 2V, 20V, 200V, 600V.  
**Resolution:** 1 mV, 10 mV, 100 mV, 1V.  
**Accuracy:** 2V: ±(0.5% + 1 digit); 20 to 600V: ±(1.5% + 1 digit).  
**AC VOLTAGE**  
**Ranges:** 200V, 600V.  
**Resolution:** 100mV, 1V.  
**Accuracy:** 200V: ±(2% + 3 digits); 600V: ±(2.5% + 3 digits).  
**RESISTANCE**  
**Ranges:** 200K, 2kK, 20kK, 200kK, 2MK, 20MK.  
**Accuracy:** 200K: ±(2% + 2 digits); 2kK to 2MK: ±(1.5% + 2 digits); 20MK: ±(2.5% + 2 digits).  
**DC CURRENT**  
**Ranges:** 2 mA, 20 mA, 200 mA, 10A.  
**Resolution:** 1µA, 10µA, 100µA, 10 mA.  
**Accuracy:** 2 to 200 mA: ±(1.5% + 1 digit); 10A: ±(2% + 1 digit).

## CONTINUITY TEST

**Range:** < 30K. **Resolution:** 0.1K.

## DIODE TEST

**Resolution:** 1 mV.

**Test Current:** 1 mA.

## TRANSISTOR (hFE) TEST

**Type:** NPN, PNP.

**Range:** 0-1000.

## LED TEST

**Test Voltage:** < 3V.

**Range:** 1.5 - 3V.

## GENERAL

**Display:** 3-1/2 digit LCD with a maximum reading of 1999.

**Sampling Rate:** 2.5 times per second.

**Ambient Operating Temperature:** 32 to 104°F (0 to 40°C), 0 to 80% RH;

**Storage Temperature:** 14 to 140°F (-10 to 60°C), 0 to 80% RH.

**Power Requirements:** One 9V battery.

**Battery Life:** 150 hrs. approx.

**Weight:** 5.2 oz (150 g).  
**Agency Approvals:** CE.

Model MM10 Digital Multimeter



Series  
TAC

# Pocket Tachometer

Non-Contact, Operation up to 30" (76 cm), Autoranging, NIST Certified

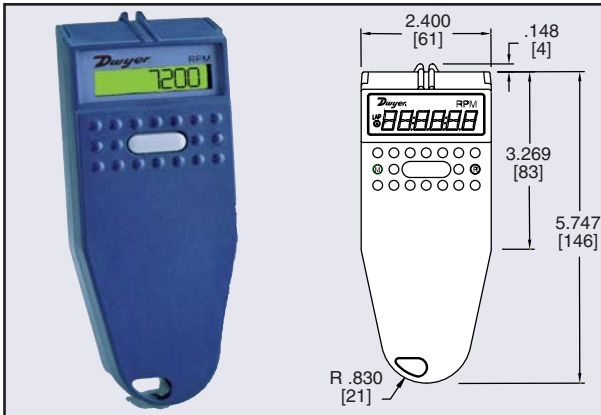

### Measurement Ranges

	Model TAC1	Model TAC2K
<b>Speed Ranges</b>		
Optical	5-100,000 rpm	5-100,000 rpm
Contact	5-20,000 w/ optional TAC1-1	2.5-20,000 rpm
<b>Linear Menu</b>		
Inches/Min*	5-20,000 (in/min only)	10-40,000
Feet/Min*	N/A	0.825-3,900
Yards/Min*	N/A	0.275-1,200
Centimeters/Min*	N/A	25-120,000
Meters/Min*	N/A	0.25-1,200
<b>Totalizer/Counter</b>	N/A	1-999,999 counts
<b>Timer (Stopwatch)</b>	N/A	99 Hrs, 59 Min, 59 Sec, 0.01 Sec

\*Also reads units per second and per hour.

Take non-contact, contact and linear speed measurements of saw blades, grinders, engines, motors and conveyor belts with the versatile Series TAC Pocket Tachometer. Unique ergonomic design provides direct line-of-sight viewing of display and target. Easy-to-read 6-digit LCD also displays on-target and low battery indication. General purpose, Model TAC1 is designed to make non-contact measurements of rotational speeds or contact measurements when equipped with the optional TAC1-1 Contact Tip Assembly. Model TAC1 comes complete with padded case, battery and 6" (15 cm) of reflective tape.

Model TAC2K is a 30 function tachometer, totalizer/counter and timer. This tachometer stores min, max and last measurement in memory and is programmable to read in English or Metric units. Optional TAC2K-91 Remote Optical Sensor allows this unit to measure rpm in hard to reach locations. Model TAC2K comes with a plastic case, contact tip assembly, linear speed wheel, battery, and 5 ft (1.5 m) of reflective tape.

### SPECIFICATIONS

**Accuracy:** Non-contact:  $\pm 0.01\%$  of reading; Contact:  $\pm 0.5\%$  of reading.  
**Display:** 6-digit alphanumeric LCD, 0.39 H.  
**Resolution:** TAC1: 1 rpm; TAC2K: User-selectable from 0.0001 to 1 rpm.  
**Max. Measuring Distance:** 30" (76 cm) and up to 30° from perpendicular.  
**Ambient Operating Temperature:** 41 to 104°F (5 to 40°C).  
**Power Requirements:** One 9V alkaline battery (included).  
**Weight:** 6 oz (170 g).  
**Agency Approvals:** CE.

Model TAC1 Pocket Tachometer . . . . .  
 Model TAC2K Pocket Tachometer Plus Kit . . . . .

### Accessories

Model TAC1-1, Contact Tip Assembly for TAC1 only.  
 Includes adapter, concave tip, and convex tip. . . . .  
 Model TAC2K-91, Remote Optical Sensor for TAC2K only.  
 Includes mounting bracket and 5 ft (1.5 m) cable . . . . .  
 Model TAC-5, Reflective Tape, 5 ft (1.5 m) roll, 1/2" (13 mm) wide . . . . .



Model  
A-800

# Proximity Switch Tester

For 2, 3 or 4 Wire DC Switches

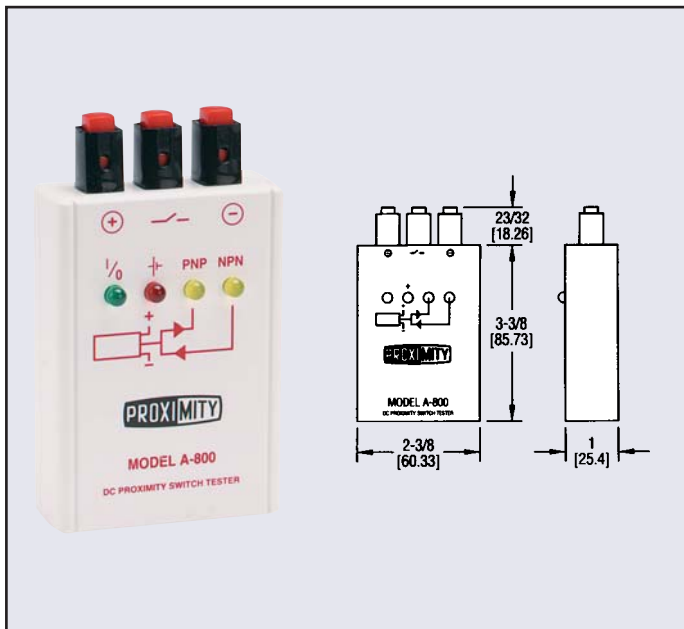

Quickly check the operation of DC proximity sensors or level switches without dismounting. Designed to test any two-, three- or four-wire sensor with a solid state switch output. The A-800 provides visual and audible indication of whether the switch is operational. Switch status (NPN/PNP) indication is designated by a yellow LED. Power "on" is indicated by a bright green LED, "low battery" is indicated by a red LED. Unit can be used with capacitive, inductive, or photo electric sensors. The pocket sized A-800 is supplied with two 9 volt batteries.

### SPECIFICATIONS

**Voltage Supply:** 18 VDC.  
**Batteries:** Two 9 volt (included).  
**Connections:** Three spring loaded terminals.  
**Housing Material:** ABS plastic.  
**Weight:** 0.77 lb (350 g).  
**Agency Approvals:** CE.

Model No. A-800 DC Proximity Switch Tester . . . . .

Test  
Equipment



Model  
WPH2

# Pocket Sized pH Tester

±0.1 pH Accuracy, Automatic Temperature Compensation, 3-pt Calibration

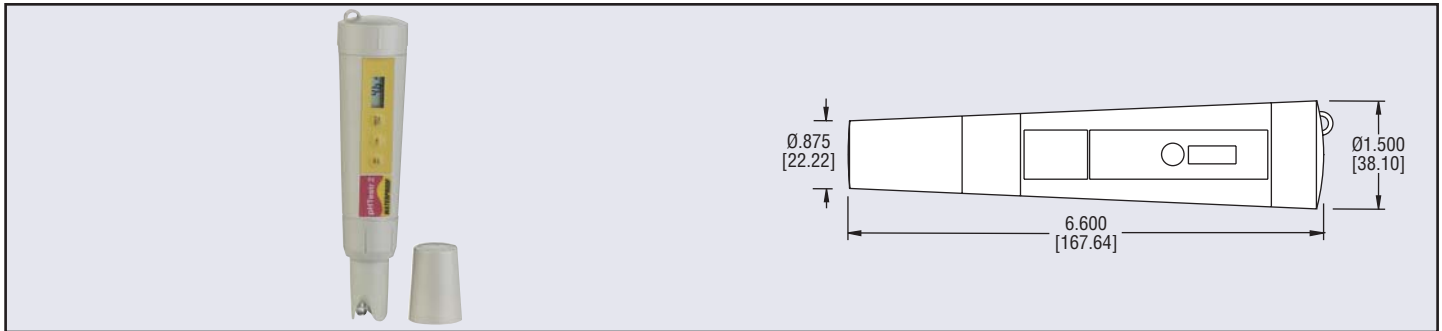

**Take fast, stable and repeatable readings** with the Model WPH2 Pocket Sized pH Tester. This microprocessor based instrument consistently delivers readings within ±0.1 pH. One-, two- or three-point push button calibration at pH 4.0, 7.0 and 10.0 let you calibrate the tester to a value near your sample to provide application versatility and better accuracy. Temperature compensation automatically corrects the reading for a more accurate measurement. Hold feature permits you to hold a reading until it can be logged. Tester turns off after 8-1/2 minutes with the Auto-Off feature. Low battery, over range and incorrect calibration error message are displayed on the large easy-to-read LCD.

**Model WPH2** Pocket Sized pH Tester

## ACCESSORIES

**WPH25** Replacement Electrode for WPH2

## SPECIFICATIONS

**Range:** -1.0 to 15.00 pH.

**Accuracy:** ±0.1 pH.

**Display:** 2-1/2-digit, 5/16" (8 mm) high LCD.

**Resolution:** 0.1 pH.

**Ambient Operating**

**Temperature:** 32 to 122°F (0 to 50°C).

**Compensated Temperature**

**Range:** 32 to 122°F (0 to 50°C).

**Power Requirements:** Three 1.5V alkaline batteries (included).

**Battery Life:** 24 hrs continuous use.

**Calibration:** 1, 2 or 3-point @ 4.0, 7.0, or 10.0 pH.

**Reference Type:** Ag/AgCl.

**Housing:** Valox®.

**Weight:** 4.5 oz (125 g).

**Agency Approvals:** CE.

## APPLICATIONS

Quick and easy pH checks in Water Conditioning Plants, Cooling Towers, Plating and Finishing Operations, Wastewater Treatment Plants and Food Processing Plants.



Model  
WPH1

# Waterproof Pocket Size pH Tester

Push Button Calibration, 0.1 pH Resolution, 0.2 pH Accuracy

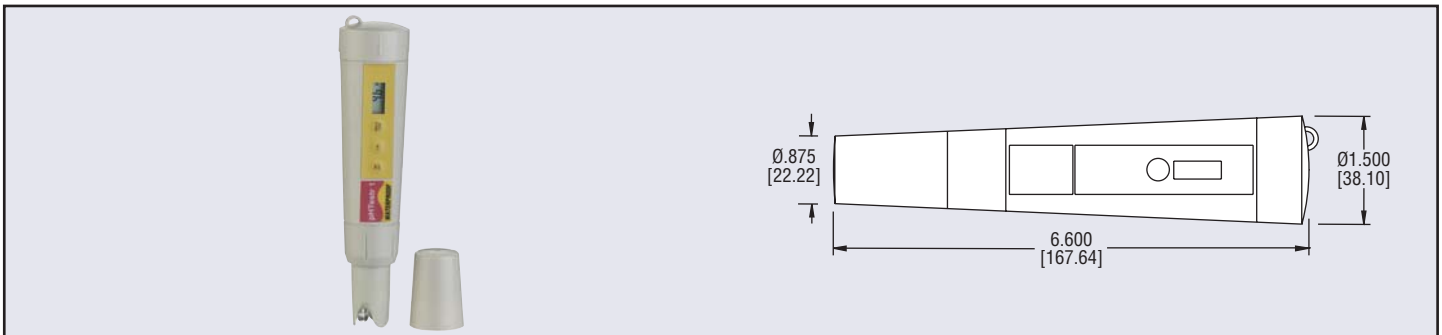

**Accurately** measure the alkaline or acidity levels of your solution with the Model WPH Waterproof pH Tester. With a push of a single button, calibrate Model WPH to meet your buffer standard of 4.0, 7.0 or 10.0 pH. Waterproof housing provides IP67 protection and will float if accidentally dropped. Built-in loop on battery compartment is ideal for attaching lanyard. Double O-ring sealed, replaceable sensor helps prevent contamination and extends the life of the tester. Standard features include automatic shut-off after 8-1/2 minutes of inactivity, display hold, low battery, over range and incorrect calibration indication.

**Model WPH1** Waterproof pH Tester

## ACCESSORIES

**Model WPH15** Replacement Electrode for WPH1

## SPECIFICATIONS

**Range:** -1.0 to 15.00 pH.

**Accuracy:** ±0.2 pH.

**Display:** 2-1/2-digit, 5/16" (8 mm) high LCD.

**Resolution:** 0.1 pH.

**Ambient Operating**

**Temperature:** 32 to 122°F (0 to 50°C).

**Power Requirements:** Three 1.5V alkaline batteries (included).

**Battery Life:** 24 hrs continuous use.

**Calibration:** Single-point @ 4.0, 7.0 or 10.0 pH.

**Reference Type:** Ag/AgCl.

**Housing Material:** Valox®.

**Weight:** 4.5 oz (125 g).

**Agency Approvals:** CE.

## APPLICATIONS

Water quality testing in pools, spas, aquariums, hydroponics, ecology studies, water and wastewater treatment, boiler/steam generators, printing and chemical industries, sanitation plants and labs.



Series  
TDS

# Total Dissolved Solids (TDS) Tester



±1% FS Accuracy, Automatic Temperature Compensation, Replaceable Sensor

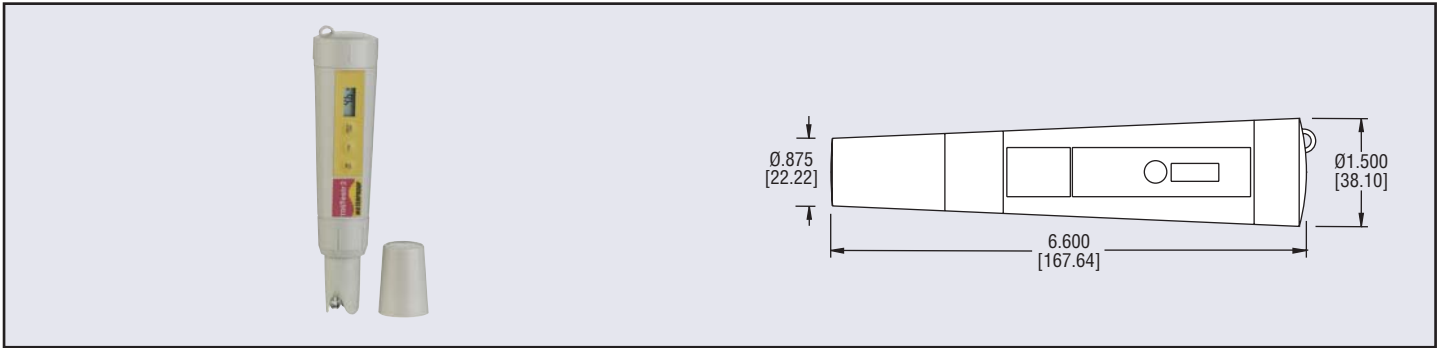

Take precise measurements of total dissolved solids with Series TDS. Lightweight and compact, these testers are ideal for field testing of TDS concentrations. Large easy-to-read LCD displays the full scale readout in ppm (parts per million)—no additional calculations are required to obtain actual test values. Durable 316 SS Electrodes provide excellent chemical compatibility. Automatic temperature compensation from 32 to 122°F (0 to 50°C) ensures reliable, repeatable results. Additional features include flip-up battery compartment, sturdy pocket clip, and a splash-resistant membrane keypad.

Series TDS2 TDS Tester, 0-1990 ppm

Series TDS3 TDS Tester, 0-10.00 ppt

TDS15 Replacement Sensor

## SPECIFICATIONS

**Wetted Materials:** 316 SS and glass reinforced thermoplastic polyester.

**Range:** TDS2: 0 to 1990 ppm; TDS3: 0 to 10.00 ppt.

**Accuracy:** ±1% FS.

**Display:** 3-1/2-digit LCD, 5/16" (8 mm) high.

**Resolution:** TDS2: 10 ppm; TDS3: 0.10 ppt.

**Ambient Operating**

**Temperature:** 32 to 122°F (0 to 50°C).

## Compensated Temperature

**Range:** 32 to 122°F (0 to 50°C).

**Power Requirements:** Four 1.5V alkaline batteries (included).

**Battery Life:** 140 hrs. continuous.

**Calibration:** 1-point push button calibration.

**Calibration Standard Range:** TDS2: 300 to 1990 ppm; TDS3: 3 to 10.00 ppt.

**Weight:** 4.5 oz (125 g).

**Agency Approvals:** CE.

## APPLICATIONS

Testing pollution controls, water treatment systems, testing for water hardness, hydroponics, and fertilizer/chemical concentrations.



Series  
EC

# Conductivity Tester



Waterproof, ±1% FS Accuracy, Large Easy to Read Display

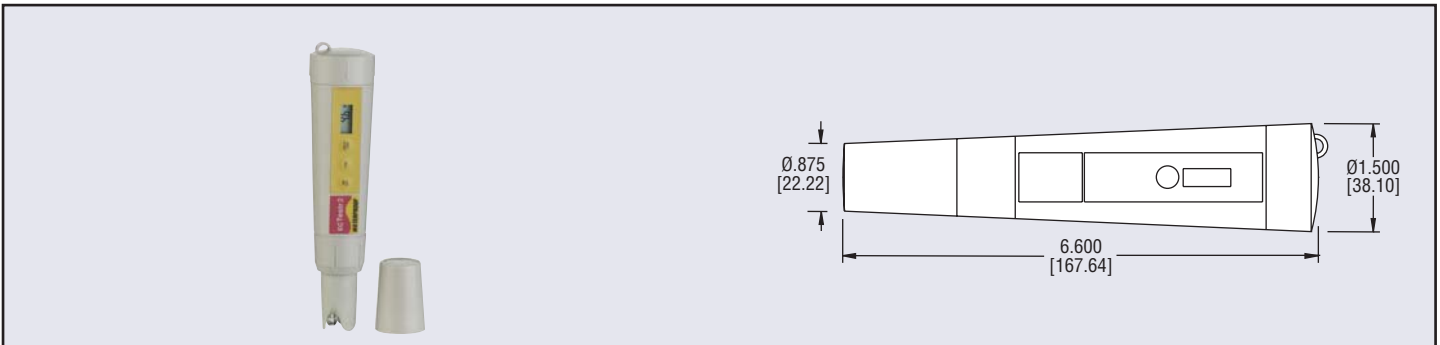

Monitor conductivity levels quickly and easily with Series EC Conductivity Testers. These pocket-sized testers are ideal for conductivity measurements in the lab, industrial plant or out in the field. Series EC measures conductivity from 0 to 1990 micromhos (µS) or 0 to 19.90 milliohms (mS). The reading is displayed on a large 3-1/2-digit LCD. Splash-proof membrane keypad prevents water damage. Glass reinforced thermoplastic polyester housing and 316 SS electrodes withstand most chemicals. Since conductivity changes with temperature, units feature automatic temperature compensation from 32 to 122°F (0 to 50°C) to ensure accurate results.

Series EC1 Conductivity Tester, 0-1990 µS

Series EC2 Conductivity Tester, 0-19.90 mS

TDS15 Replacement Sensor

## SPECIFICATIONS

**Wetted Materials:** 316 SS and glass reinforced thermoplastic polyester.

**Range:** EC1: 0 to 1990 µS; EC2: 0 to 19.90 mS.

**Accuracy:** ±1% FS.

**Display:** 3-1/2-digit LCD, 5/16" (8 mm) high.

**Resolution:** EC1: 10 µS; EC2: 0.10 mS.

**Ambient Operating Limits:** 32 to 122°F (0 to 50°C).

## Compensated Temperature

**Range:** 32 to 122°F (0 to 50°C).

**Power Requirements:** Four 1.5V alkaline batteries (included).

**Battery Life:** 140 hrs. continuous.

**Calibration:** 1-point push button calibration.

**Calibration Standard Range:** EC1: 300 to 1990 µS, EC2: 3 to 19.90 mS.

**Weight:** 4.5 oz (125 g).

**Agency Approvals:** CE.

## APPLICATIONS

Monitor conductivity levels quickly and accurately to determine water hardness, check pollution control, recirculating systems, and waste water.

Test  
Equipment



Model  
M

# SAFE-T-OHM® Shoe Tester

For Electrostatic Dissipating (ESD) Footwear

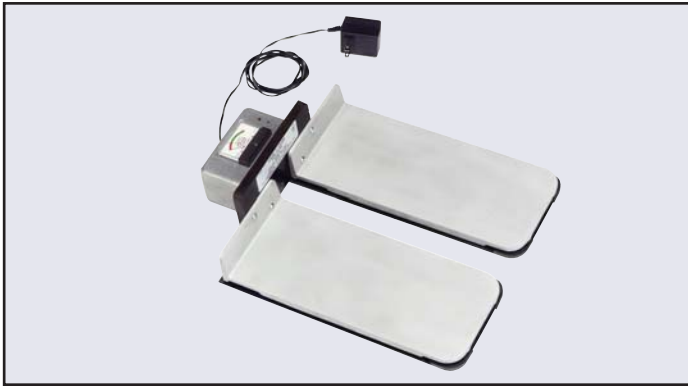

- Dual foot plates provide increased accuracy and dependability
- Quick and Easy to Use for All Personnel
- Direct Reading Analog Scale and Dual LED Go/No-Go Indicators

### SPECIFICATIONS

**Power Requirements:** 115 VAC, 50/60 Hz

**Protective Circuitry:** UL approved Class II transformer, one megohm current limiting resistors in series with each shoe plate.

**Accuracy:** ±1% at both minimum and maximum of range.

**Size and Weight:** 12 x 17 inches (30.5 x 43.2 cm); 8 lb (3.5 kg)

**Installation:** Clean, dry, static-free floor. Carpeting not recommended.

### MODELS

Model Number	Megohm Range*
M-1	2-20
M-2	20-200
M-3	200-2000

\*All scales read zero to infinite resistance. Megohm Range indicates the limits of acceptable resistances as shown in green on the color coded scale. Select the appropriate model for the resistance rating of the ESD footwear specified for use in your facility.

### Accessories (order separately)

A-133; Rubber Shoe Cleaning Tray

A-134; Shoe Cleaner Pad

Simply stand on the heavy-duty sandblasted aluminum foot plates and the SAFE-T-OHM® automatically measures the resistance of your ESD footwear. It provides an accurate direct readout on a full-range, color coded scale and "Go/No-Go" status-at-a-glance with dual LED indicators which are calibrated at common ESD threshold levels. The Model M combines rugged design with solid-state technology tailored for the demands of the electronics industry where accurate, dependable static control monitoring is essential.



Model  
TR-7

# SAFE-T-GROUND

Explosion-proof, Intrinsically Safe, Ground and Continuity Control



TR-7L pictured

losion, compared to single wire grounding, which cannot measure the quality of the electrical ground connection during loading. The transistorized TR-7 circuit generates little heat - an added safety feature. The Model TR-7 Safe-T-Ground is simple and easy to install. Removal of the cover on the explosion-proof aluminum housing reveals the easily accessible terminal strip for relay and ground control wiring, and a complete schematic wiring diagram appears on a label next to the terminal strip for easy wiring. Coiled grounding cable/contactor-handle assembly is easily replaced via mil-spec connector on housing.

### SPECIFICATIONS

**Housing:** 356-T6 Cast aluminum alloy (copper-free), explosion-proof - Class I, Group D.

**Size:** 6-5/8" W x 10-3/8" H x 5-5/8" D.

**Power Requirements:** 105-125 VAC, 60 Hz. 7.75 watts - with light, 1.75 watts - without lights.

**Electrical Rating, Relay:** DPDT, 10 amps, 125 VAC, 60 Hz. contact rating. Optional 220-240 VAC, 50/60 Hz - call factory.

**Wiring Hookup:** On terminal strip.

**Conduit Connection:** 3/4" NPT

**Installation:** 7/16" mounting lugs, integrally cast.

**Contactors:** (Grounding clamp) molded polyethylene with beryllium copper contact clips. 16-2 type SO coiled cable; retracts to 3', extends to 16'.

**Grounding Studs:** 2 supplied. Order a pair for each truck.

**Shipping Weight:** 20 lb with contactor and cord.

**Options:** Integral pilot lights; 30' coiled cable; temporary contactor assemblies, clamp connectors, and other supply voltages.

**Model TR-7 Safe-T-Ground** provides continuous monitoring of a truck's ground connection throughout loading operations. Static electricity is often brought in by tank trucks entering the loading area. The Safe-T-Ground Model TR-7 instantly stops loading operations if a tank truck loses its ground. The simple but rugged Model TR-7 circuit continuously measures resistance through the truck by applying a small voltage to one terminal of the truck grounding contactor. The other terminal is connected to the loading rack ground. If the Safe-T-Ground detects a resistance of more than a few ohms across the contactor terminals, the relay opens, breaking the control circuit. The relay will not close until the grounding contactor is properly connected.

To safeguard loading operations, the Safe-T-Ground circuit can be wired into your pump control - and to an audible alarm or signal light.

The double wire TR-7 system provides an extra safeguard against ex-

### Model TR-7

### Model TR-7-L (Integral Pilot Lights)



Series DT

# Detector™ Position Sensor

Reliable Magnetic Point Sensor, Stainless Steel Housing, AC or DC

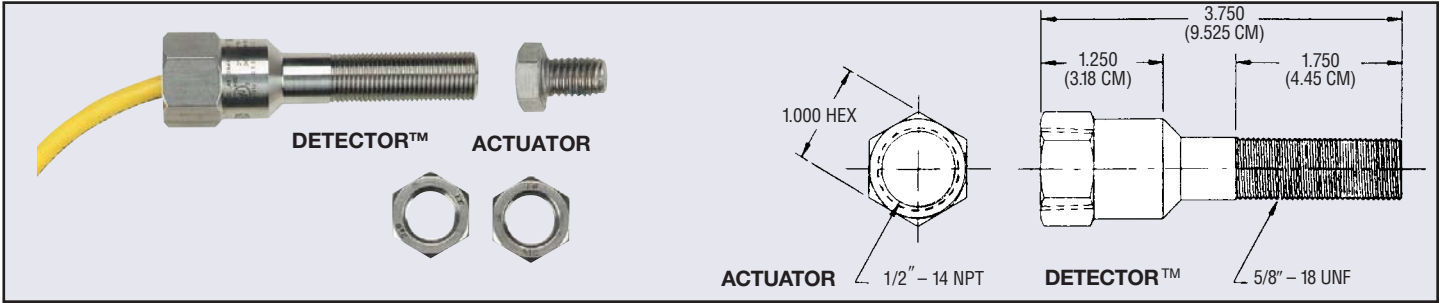

**Proximity Detector™ Position Sensors** are reliable, magnetically actuated, stainless steel, completely interchangeable with competitive units. AC or DC for user friendly operation. They have no moving parts, eliminate costly seal fittings and offer enhanced reliability by eliminating arcing. Unintentional actuation by metals is not a problem. The sensor consists of a durable hermetically sealed reed switch potted in a stainless steel housing and a separate 316 stainless steel magnetic actuator bolt. As the actuator moves within the sensing range of the sensor, the magnet in the actuator changes the state of reed switch contacts inside the sensor. This either opens or closes a circuit depending on wiring configuration. Sensing distance is 0.1" (2.54 mm) for the standard actuator. Greater sensitivity of a larger magnetic actuator increases the sensing distance to 0.5" (12.7 mm).

The Detector™ is excellent for hazardous and corrosive environments, solid state and intrinsically safe applications. A Detector may be mounted in any position. For installation in hazardous locations be sure to check local and national electrical codes. The Detector is designed to NEMA 1, 3, 4, 4X, 6, 7, 9, 12 and 13.

### SPECIFICATIONS

**Temperature Limits:** -40 to 163°F (-40 to 73°C).

**Switch Type:** Tungsten, SPDT, Form C.

**Electrical Rating:** 3A @ 125 VAC, 3A @ 30 VDC.

**Enclosure Rating:** Weatherproof; Hermetically Sealed; Explosion-proof UL & CSA Listed for Class I, Groups A, B, C, & D; Class II, Groups E, F & G. Divisions 1 & 2.

**Intrinsically Safe:** Simple Apparatus (w/ barrier).

**Operating/Response Time:** 3.0 m Sec.

**Initial Contact Resistance:** 0.50 ohms (Max).

**Repeatability:** 0.005 in. (.01 cm).

**Hysteresis:** 0.030 in. (.08 cm).

**Electrical Connection:** Factory sealed leads with 18" minimum, 4 conductor, PVC insulated, 18 AWG - Green/Red/Black/White (Ground/NC/NO/Common).

**Housing:** 316 SS.

**Potting:** Epoxy Resin.

**Conduit:** 1/2"-14" female NPT.

**Weight:** 0.32 lb (145 g); 0.45 lb (204 g) with actuator.

### MODELS AND ACTUATOR SIZES

Model No.	Description	Sensing Distance
DT1060	Detector™ and standard actuator	0.1" (2.54 mm)
DT1160	Detector™ and high strength actuator	0.5" (12.7 mm)

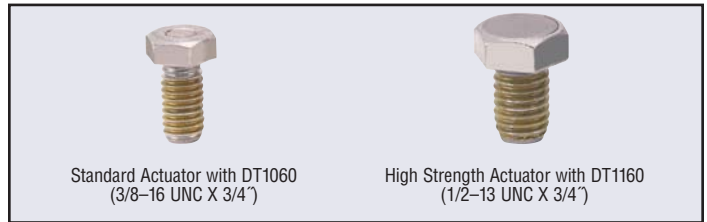

Series PS

# Proximity Sensors

Capacitive or Inductive 3-Wire DC, Threaded Body



The diagram shows two types of Proximity Sensors: the PSC Series (red) and the PSI Series (stainless steel). A table provides dimensions for four models: PSC20103, PSC20203, PSI2002203, and PSI2005303. Dimensions A, B, C, D, and E are defined in the diagram.

Dim.	PSC20103	PSC20203	PSI2002203	PSI2005303
A	M18	M30	M12	M18
B	1.065 (27)	1.614 (41)	0.688 (17)	0.938 (17)
C	0.157 (4)	0.197 (5)	0.125 (3)	0.125 (3)
D	3.156 (80)	3.156 (80)	2.36 (60)	2.87 (73)
E	2.36 (60)	2.36 (60)	1.58 (40)	1.97 (50)

**The Series PS Proximity Sensors** are noninvasive sensors ideal for level detection, position indicating and counting applications. Capacitive type sensors detect electrically conducting and nonconducting materials, liquids, solids, or powders and include a sensitivity adjustment to differentiate between various materials. Inductive sensors detect ferrous or nonferrous metals only. A bright LED indicates the state of the output switch. Sensors feature short circuit, reverse polarity, and transient protection. Small size and threaded body make installation easy. Inductive sensors are embeddable (can be mounted flush). Capacitive sensors are environmentally protected to IP65 and Inductive sensors are protected to IP68. Units include two fixing, screwdriver, and operating manual.

### MODELS

Model Number	Type	Body Size	Switching Frequency	Detecting Dist. in (mm)
PSC20103	Cap.	M18	400 Hz	.04-3 (1-10)
PSC20203	Cap.	M30	250 Hz	.08-79 (2-20)
PSC30203*	Cap.	M30	250 Hz	.08-79 (2-20)
PSI2002203	Ind.	M12	800 Hz	.08 (2)
PSI2005303	Ind.	M18	500 Hz	.19 (5)

\*NPN Transistor

### SPECIFICATIONS

**Wetted Materials:** Glass reinforced plastic (PSC), Stainless Steel (Model PSI2002203), Nickel-plated Brass (Model PSI2005303).

**Temperature Limits:** -22 to 212°F (-30 to 100°C) capacitive, -13 to 158°F (-25 to 70°C) inductive.

**Enclosure Rating:** PSC, IP65; PSI, IP68.

**Repeatability:** ±0.05% (Model PSC20103), ±0.1% (Model PSC20203 ±0.01% (PSI Models).

**Power Requirements:** 8 to 30 VDC.

**Switch Type:** Normally open NPN transistor, sinking.

**Electrical Rating:** 250 mA (PSC), 200 mA (PSI).

**Minimum Load Current:** 8 mA (PSC), <25 mA (PSI).

**Leakage (Off-State) Current:** <3 mA (PSC), <0.08 mA (PSI).

**Voltage Drop:** <3.5V @ 250 mA (PSC), <2.5V @ 200 mA (PSI).

**Ripple:** 10%.

**Electrical Connection:** 9.8 ft (3 m) cable.

**Deadband:** 20% of range (PSC), 15% of range (PSI).

**Initializing Time Delay:** <10 msec.

**Agency Approvals:** CE.

Test Equipment



Model  
SSR-15

# Intrinsically Safe Relay

SPST Switch Operation, 5 Amp

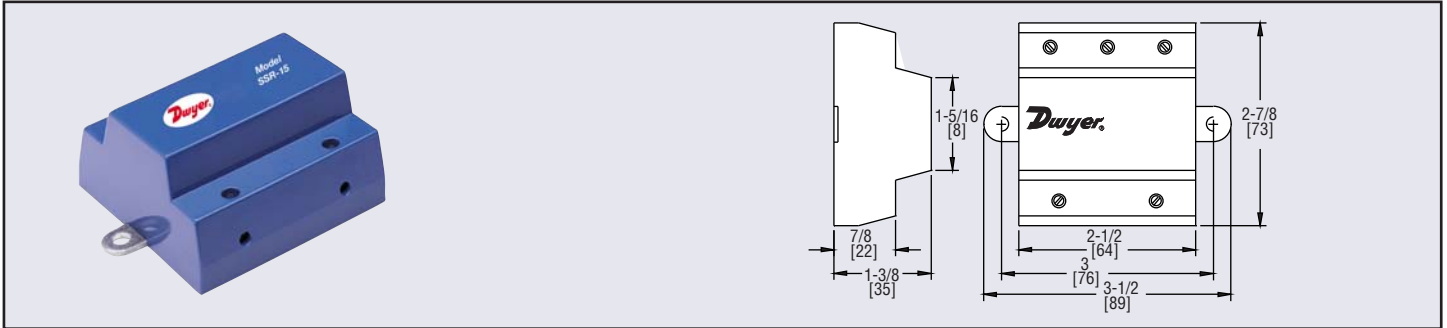

**Model SSR-15 Intrinsically Safe Relay** offers low power switching with solid state reliability and eliminates explosive conditions. Units are completely encapsulated and impervious to dust, moisture, or foreign material. Model SSR-15 can be mounted in any orientation and is shock and vibration resistant.

SSR-15 Intrinsically Safe Relay . . . . .

## SPECIFICATIONS

**Operating and Load Voltage Range:** 105 to 125 VAC.  
**Max. Load Current:** 5 Amp.  
**Switching Operation:** SPST normally open.  
**Sensitivity:** Turn-on: 500; Turn-off: 2000Ω.  
**Temperature Limits:** -40 to 120°F (-40 to 49°C).

**Voltage Loss:** 2 VAC.  
**Max. Output Leakage Current:** 6 mA @ 120 VAC.  
**Housing:** Polysulfone.  
**Weight:** 9 oz (255 g).  
**Agency Approvals:** Rated explosion-proof for Class I, II, Div. 1 & 2, Groups A, B, C, D, E, F, G. UL, CSA, FM, and MSHA.



Series  
SSR

# Solid State Relay

5 or 10 Amp, SPST Switch Operation

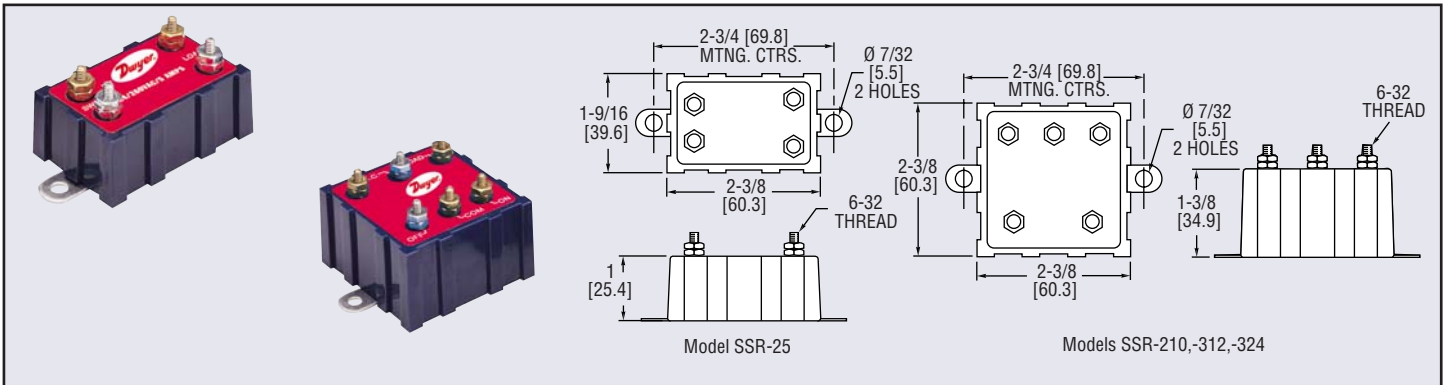

**Series SSR Solid State Relays** amplify the current handling capability of a variety of sensors for controlling higher power loads. The relays are compact, totally encapsulated and impervious to shock or vibration. Units feature SPST, normally open switch operation and can control loads up to 5A or 10A depending on model. Models SSR-312 and SSR-324 are specifically designed to provide low current "start-stop" or "on-off" switching for industrial motor, liquid level, and other control systems. Units hold operational state up to a 1/2 second during momentary power loss to cut nuisance shutdowns.

## MODELS

Current Amplifying		
Model Number	Operating Range	Max. Load
SSR-25*	24 to 260 VAC	5 Amp
SSR-210*	24 to 260 VAC	10 Amp
On/Off Control		
Model Number	Operating Range	Max. Load
SSR-312	100 to 130 VAC	5 Amp
SSR-324	200 to 250 VAC	5 Amp

## SPECIFICATIONS

**Operating and Load Voltage Range:** SSR-25 and SSR-210: 24 to 260 VAC; SSR-310: 100 to 130 VAC; SSR-324: 200 to 250 VAC.  
**Maximum Sensor Current:** 20 mA.  
**Switching Operation:** SPST normally open.  
**Temperature Limits:** 0 to 120°F (-18 to 49°C).  
**Voltage Loss:** 2 VAC.  
**Leakage Current:** Thru load terminal: 12 mA @240 VAC.  
**Max. Output Leakage Current:** 6 mA @ 120 VAC.  
**Housing:** Polysulfone.  
**Weight:** 9 oz (255 g).  
**Agency Approvals:** CE.

Test  
Equipment



Series  
CT40/50

# Current Transformer

4-20 mA or 0-5 VDC Output, Split Core Case

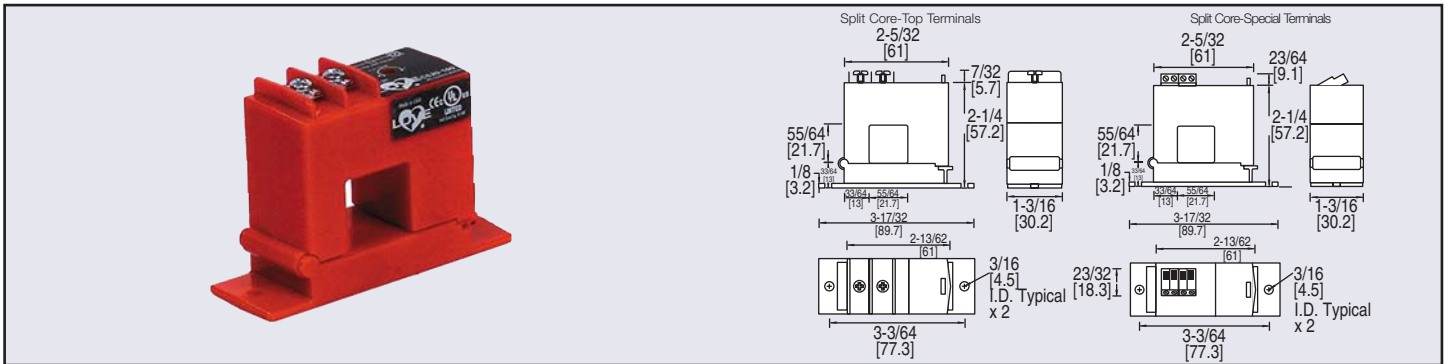

Series CT40/50 combine current transformer and signal conditioner into a single package. Transformers feature jumper selectable ranges and split core case. Units are designed for applications on linear or sinusoidal AC loads.

## MODELS

Model Number	Range	Output	Power Requirements
CT40-100	10/20/50 A	4-20 mA	12-40 VDC, Loop Powered
CT40-102	10/20/50 A	0-5 VDC	Self Powered
CT50-100	100/150/200 A	4-20 mA	12-40 VDC, Loop Powered
CT50-102	100/150/200 A	0-5 VDC	Self Powered

## SPECIFICATIONS

- Output Signal:** 0-5 VDC or 4-20 mA, depending on model.
- Power Requirements:** See Table.
- Accuracy:** CT40/50-102: 1.0% FS; CT40/50-100: 0.5% FS.
- Temperature Limits:** -4 to 122°F (-20 to 50°C).
- Response Time:** CT40/50-102: 100 ms; CT40/50-100: 300 ms.
- Isolation Voltage:** 1270 VAC.
- Frequency:** CT40/50-102: 50-60 Hz; CT40/50-100: 20-100 Hz (Sinusoidal waveforms only).
- Enclosure Rating:** UL 94V-0 flammability rated.
- Agency Approval:** CE.



Series  
CT60/70

# True RMS Current Transformer

Field Selectable Range, Split Core Case

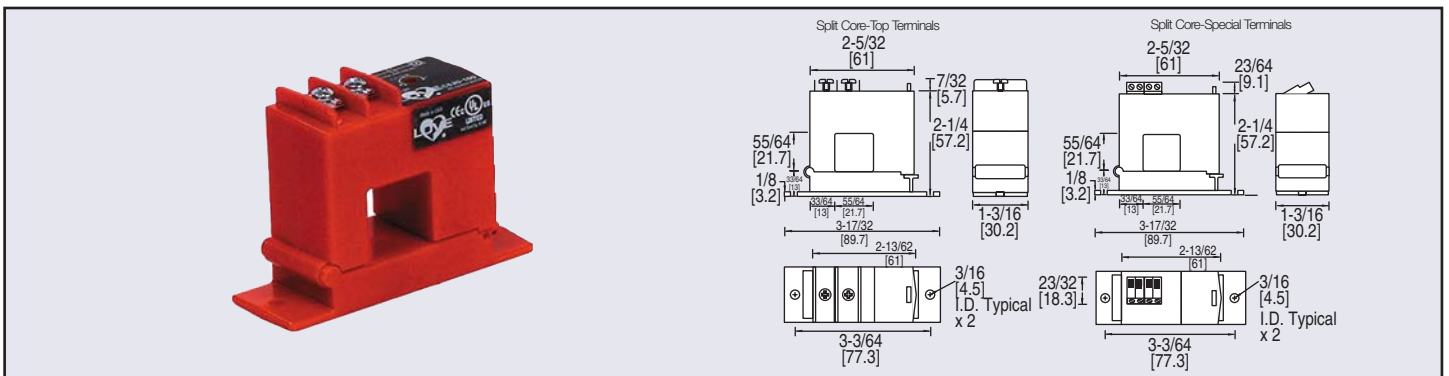

Series CT60/70 Current Transformers provide true RMS output on distorted AC waveforms – ideal for nonlinear loads or noisy environments. Each model offers three jumper selectable ranges and 1270 VAC isolation. Split core case allows easy installation.

## MODELS

Model Number	Range
CT60-100	10/20/50 A
CT70-100	100/150/200 A

## SPECIFICATIONS

- Output Signal:** 4-20 mA, loop powered, true RMS.
- Power Requirements:** 24 VDC nominal.
- Accuracy:** 0.8% FS.
- Temperature Limits:** -4 to 122°F (-20 to 50°C).
- Response Time:** 600 ms to 90%.
- Isolation Voltage:** 1270 VAC.
- Frequency:** 10-400 Hz.
- Enclosure Rating:** UL 94V-0 flammability rated.
- Agency Approval:** CE.



Series  
CS

# Current Switches

Universal Output, Solid or Split Core Case

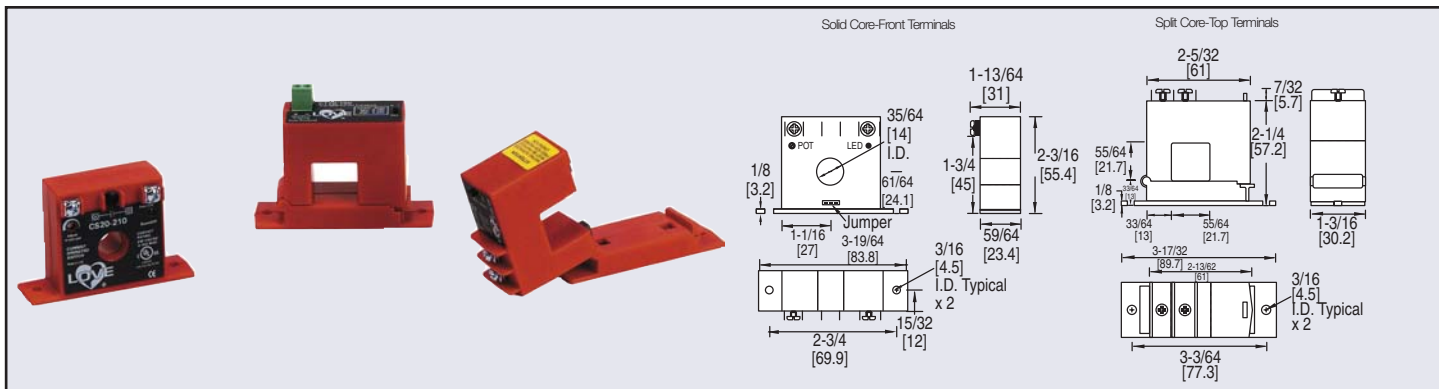

The CS Series Current Switches combine a current transformer, signal conditioner and limit alarm into a single package. The CS series has an extended current input range, universal solid-state outputs and a wide frequency response. Available in a split core or a solid core case. Switches feature LED indication for local display or switch status.

### MODELS

Model Number	Setpoint Range	Core	Voltage
CS20-100	Adj. 1.75-150A	Split	240 VAC/DC
CS20-220	Adj. 1-150 A	Solid	240 VAC/DC
CS40-220	Selectable 1-6, 6-40, & 40-175A	Solid	240 VAC
CS50-100	Selectable 1-6, 6-40, & 40-175A	Split	240 VDC

### SPECIFICATIONS

- Output:** Isolated, normally open.
- Power Requirements:** None, self powered.
- Temperature Limits:** -58 to 149°F (-50 to 65°C).
- Hysteresis:** 5% of output.
- Response Time:** CS20: 0.120 sec; CS40/50: 0.04 to .120 sec.
- Isolation Voltage:** 1270 VAC.
- Frequency:** 6-100 Hz.
- Enclosure Rating:** UL, V-O flammability rated, ABS plastic housing.
- Agency Approvals:** CE.



Model  
FC-1000

# Electronic Fan Speed Control

Low Cost, 0-10 VDC Input, Selectable Hard Start

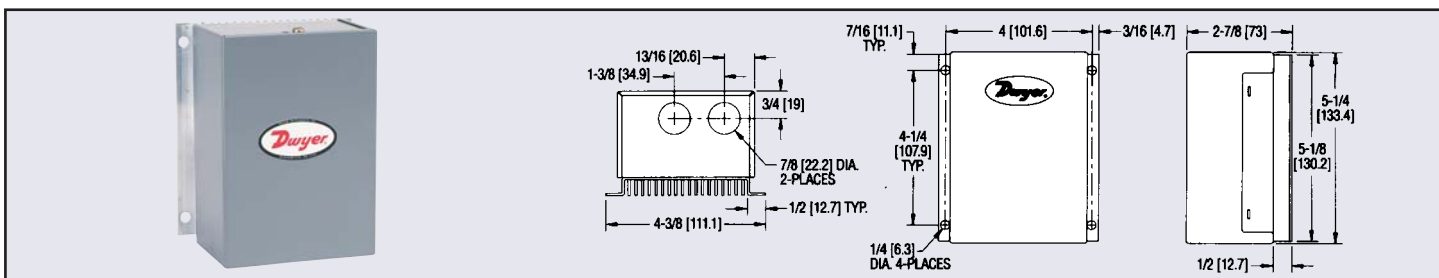

The Model FC-1000 Electronic Fan Speed Control provides precise speed modulation of small AC motors. Popular 0-10 VDC input works with most process controllers, eliminating the need for more expensive dampers, damper actuators and linkages while improving overall energy efficiency of the system. This inexpensive unit enables variable control of ventilation fans, condenser fans and interfacing with VAV box controllers.

Model FC-1000 Electronic Fan Speed Control.....

### SPECIFICATIONS

- Line Voltage Range:** 120-277 VAC, 60 Hz.
- Input Signal Voltage:** 0-10 VDC.
- Low Voltage Input:** 24 VAC, Class 2.
- Input Signal Impedance:** 10K ohms.
- Full Load Amp Rating:** 9.8 @120 VAC, 9.3 @ 208 VAC, 8.0 @ 240 VAC 6.9 @ 277 VAC.
- Locked Rotor Amp Rating:** 24.0.
- Temperature Limits:** -40 to 131°F (-40 to 55°C).
- Electrical Connections:** Line Voltage: 10-32 screw terminals. Signal and low voltage input: 1/4" quick connects.
- Transient Protection:** 320 V surge suppression. Exceeds IEEE C62.41 standards.
- Housing Materials:** Cold rolled steel.
- Enclosure Rating:** NEMA 1.
- Mounting:** Vertical only; four holes provided for #10 screws.
- Weight:** 1 lb, 11 oz (.77 kg).
- Agency Approval:** UR.

Test  
Equipment

# Related Products and Accessories



## Model A-699 Control Transformer

UL and CSA listed Class 2 step down transformer is mounted on a 4-1/4" square plate stand-off for direct installation in standard 4" x 4" x 1-1/2" junction boxes. The A-699 is suitable for powering all Dwyer 4-wire transmitters and Model 660 Air Velocity Monitor.

### SPECIFICATIONS

**AC Input:** 120 VAC, 60 Hz.

**AC Output:** 24 VAC.

**Maximum Current output:** 400 mA (typically). 10 VA max.

**Electrical Connections:** Primary, 6-1/2" leads; Secondary, 6-32 screw terminals.

(Manufactured for Dwyer Instruments, Inc.)

**Weight:** 1 lb, 4 oz.

A-699 Control Transformer



## Series 1000 Process Indicator and Alarm

Low cost 1/16 DIN units provide 3-1/2 digit, 0.3" high LED readings from four field selectable input ranges. Includes integral power supply to operate 2-wire transmitters. Optional low/high SPST alarm relays can be set for direct or reverse action. 1.88" H x 1.88" W x 5.05" D (48 x 48 x 128 mm).

### SPECIFICATIONS

**Supply Voltage:** 100-240 VAC. 132-240

VDC.

**Input Ranges:** 4-20 mA, 0-100 mV, 0-1 V or 0-10 V.

**Optional Relay Ratings:** 3A @ 250 VAC resistive, 1.5A @ 250 VAC inductive. Pilot duty – 250 VA, 2A @ 125 VAC or 1A @ 250 VAC.

**Temperature Range:** 32 to 122°F (0 to 50°C).

**Weight:** 6.5 oz (185 g).

1000 Process Indicator  
1010 Process Indicator w/Alarm



## Series AN14 Indicating Annunciator

Four input, 1/8 DIN annunciator is ideal for any application where pressure, temperature, level or flow switches require visible and audible alarms. Two annunciators can be easily wired together to form an eight input system. Field selectable logic for ISA Sequence A (momentary or maintained alarms) or ISA Sequence F2A (momentary or maintained with first out). LED alarm and power indication on a NEMA 4 front panel. 1.64"H x 3.59"W x 4.13"D (42 x 91 x 105 mm).

### SPECIFICATIONS

**Inputs:** NO or NC switches; Open Collector Transistor (Open circuit voltage = 5 VDC); Logic Levels: LO = 0 to .8 VDC, HI 4.7 to 28 VDC (100 kK input impedance).

**Outputs:** SPDT relay (5A @ 240 VAC, resistive), Audible alarm (75 dB), four red indicating LEDs.

**Ambient Operating Temperature:** 14 to 149°F (-10 to 65°C).

**Power Requirements:** 117 or 230 VAC ±10%, 50/60 Hz, 3VA.

**Electrical Connections:**

Removable screw terminal block, accepts 24 to 12 AWG.

**Mounting:** 1/8 DIN.

**Housing Material:** ABS plastic.  
**Enclosure Rating:** NEMA 4 front panel.

**Weight:** 11.4 oz (325 g).

AN14-1 (117 VAC)  
AN14-2 (230 VAC)

# Related Products and Accessories



## Model A-700 Power Supply

Economical and reliable power supply is suitable for powering all Dwyer pressure, temperature or air velocity transmitters. Inexpensive, open-frame design allows convenient access to input/output solder terminals. Auxiliary inputs are selectable for operation from power sources found worldwide. Compact size eases enclosure installations: 4-7/8"H x 4"W x 1-5/8"D.

**A-700** (0.5 Amp)  
**A-700-2** (2 Amp)  
**A-700-4** (4.8 Amp)

### SPECIFICATIONS

**AC Input:** 100/120/220/230-240 VAC ±10%, 47-63 Hz.  
**DC Output:** 24-28 VDC regulated.  
**Maximum Current Output:** 500 mA (de-rated to 450 mA @ 50 Hz operation)  
**Ambient Operating Temperature:** 32 to 122°F (0 to 50°C).  
**External Fuse Required:** 0.5 Amp for 100-120 VAC, 0.25 Amp for 220-240 VAC.  
**Weight:** 2 lb.



## Model A-701 Digital Panel Meter/Power Supply

3-1/2 digit, 0.6" high LED display is combined with an integral 24 VDC power supply to provide a complete digital indicating system when used with Dwyer 2-wire transmitters. Standard unit is supplied to read 0-100.0% and is field adjustable from 1.999 to 1999 for readout of actual engineering units. Panel mounting hardware included. 1/8 DIN size: 1.64"H X 3.59"W X 4.13"D.

**A-701** Digital Panel Meter

### SPECIFICATIONS

**AC Input:** 120 VAC ±15%, 50/60 Hz.  
**Input Impedance:** 40 ohms.  
**Accuracy:** ±0.05% of reading.  
**DC Output:** 24 VDC regulated.  
**Maximum Current Output:** 50 mA.  
**Operating Temperature:** 32 to 122°F (0 to 50°C).  
**Power Consumption:** 6 watts.  
**Weight:** 12 oz (340 g).



## Model A-705-20 Loop Powered Process Indicator

Economical, short depth (0.5" behind panel) unit is a 4-20 mA loop powered process indicator with 0.6" LCD display. This bipolar 3-1/2 digit panel meter fits standard 1/8 DIN cutout and includes adjustable scale (gain), offset and decimal point selection for quick field calibration. Standard model supplied 0-100.0% for 4-20 mA input.

**A-705-20** Process Indicator

### SPECIFICATIONS

**Display Range:** 000 to ±1999.  
**Inputs:** 4-20 mA or 10-50 mA.  
**Accuracy:** ±1% of reading, ±1 digit.  
**Resolution:** Selectable, 1.XXX, 1X.XX, 1XX.X, 1XXX.  
**Ambient Operating Temperature:** 32-122°F (0-50°C).  
**Power Requirements:** None required, powered by current source.  
**Temperature Coefficient:** 100 ppm /°C typical.  
**Polarity:** If negative input, minus sign at left.  
**Panel Cutout:** 3.62"W x 1.69"H (92 x 43 mm).  
**Dimensions:** 1.91"H x 4"W x 1.115"D (48 x 101.6 x 28.3 mm).  
**Weight:** 2 oz (57 g).