

Adsorption Dryer HRE

- Desorption in counter current flow to the adsorption direction with externally heated blower air
- Cooling in counter current flow with a depressurized partial stream of dried compressed air

ADSORPTION

The compressed air flows through the unit inlet (J) via the inlet valve (K1) and the flow distributor, passing through the bed of desiccant from bottom to top. The flow distributor ensures that the compressed air is evenly distributed throughout the adsorption vessel.

While the (still) humid stream of compressed air passes through the system, the vaporized water is adsorbed by the hygroscopic desiccant. The dried compressed air enters the compressed air network (O) via the upper outlet flow distributor and the outlet valve (R1). The drying process is terminated either after a certain

time has elapsed or subject to the dew point (OPTION).

The adsorption proceeds from bottom to top (figure 1).

Legend:

- J = wet air inlet
- O = dry air outlet
- Rj = desorption air inlet
- Ro = desorption air outlet
- Cj = cooling air inlet
- Co = cooling air outlet

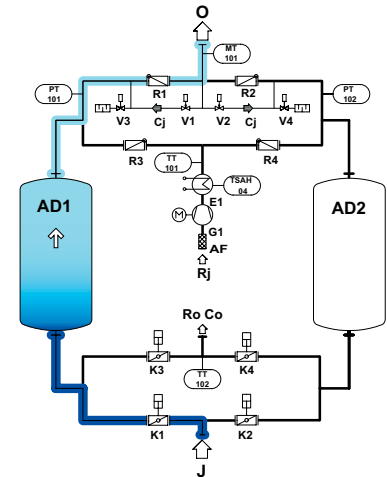

Fig. 1: AD1 Adsorption

ADSORPTION - DESORPTION

One adsorber is regenerated (here AD2) whilst adsorption takes place in the other vessel (here AD1) of the unit. Before the regeneration may begin in the respective adsorber, the pressure is slowly reduced to normal atmospheric level. Units of the HRE series use ambient air for their desorption (Rj).

A blower (G) compresses the ambient air to the pressure level needed for the regeneration. The resulting temperature increase positively affects the power needs of the downstream heater (E) which heats up the air from the blower until it has reached the required desorption temperature.

The heated air from the blower is led via the regeneration mounting (R4) into the adsorber, which currently has to be desorbed.

The air is equally distributed and flows through the entire bed of desiccant, evaporating the water contained in the desiccant. This water load is

being driven out to atmosphere on the shortest way via the regeneration valves (here K4).

The heated ambient air cools down when flowing through the vessel as a result of the evaporation of the water. The temperature of the outgoing moist air is therefore not higher than the evaporation temperature (approx. 40-60°C).

The amount of moisture in the desiccant diminishes during the desorption process and the temperature at the regeneration air outlet (Ro) rises.

The desorption phase is terminated once the required process temperature has been reached.

In contrast to the direction followed by the adsorption, the desorption proceeds from top to bottom using externally heated blower air.

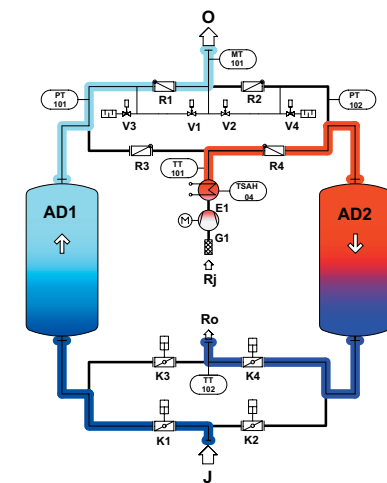

Fig. 2: AD1 Adsorption / AD2 Desorption

Adsorption Dryer HRE

ADSORPTION - COOLING

The subsequent cooling of the heated desiccant is effected by a depressurized partial flow of already dried compressed air (Figure 3).

The desiccant is not pre-loaded with moisture, since dried compressed air is used. Furthermore, a post-desorption process takes place during the cooling-down phase, improving the quality of the regeneration along the way.

The regeneration outlet valve (here

K4) closes after the cooling-down phase has come to a close. Subsequently the pressure is built up slowly in the regenerated adsorber vessel (here AD2). The pressure is balanced slowly (by valve V1 and V2), thus ensuring a careful and efficient use of the desiccant.

The standby phase begins as soon as the pressure has been balanced.

Cooling proceeds from top to bottom using a depressurized partial stream of dried compressed air.

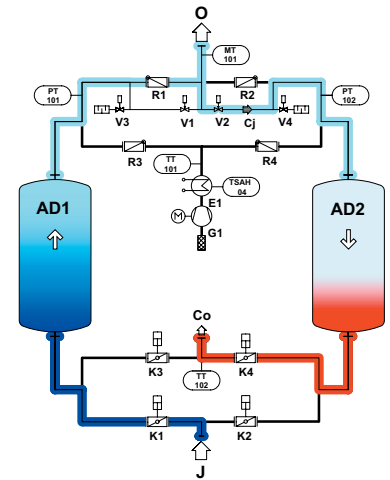

Fig. 3: AD1 Adsorption / Kühlung

ADSORPTION - STANDBY

Whilst one adsorber (here AD1) is continuously in adsorption phase, the second one (here AD2) is ready to switch over.

The duration of the standby phase (Figure 4) is subject to various parameters. It is especially important whether the customer uses the facility regularly or irregularly.

There are two different ways to set the control function:

- time dependent
- dew point dependent (OPTION)

a. „Time dependent“ means that the cycle times are fixed, regardless of how much vaporized water is actually contained in the desiccant.

b. „Dew point dependent“ means that the cycle times depend on the amount of moisture present. The cycles are switched when a certain pre-set dew point has been attained at the outlet. The adsorption vessels are only switched over once the capacity of the adsorption agent to absorb moisture has been exceeded.

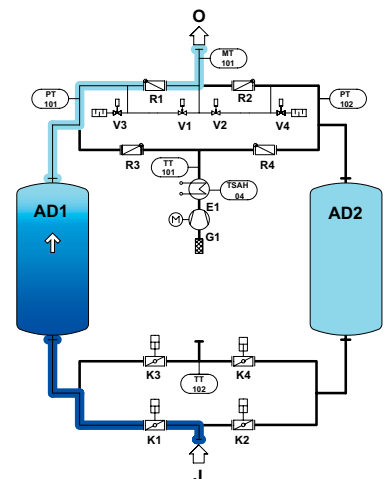

Fig. 4:
AD1 Adsorption / AD2 Standby

PARALLEL OPERATION

Before the adsorbers can be switched over (here from AD1 to AD2), they will (for a short period) be operated simultaneously.

For about ten minutes, the compressed air flows through both adsorber vessels (figure 5).

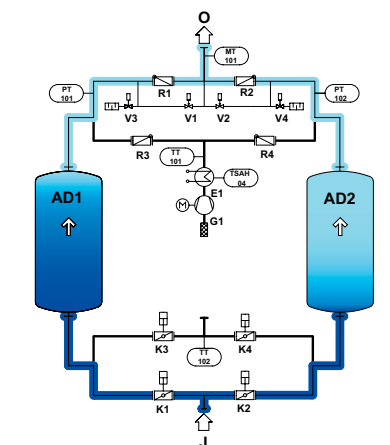

Fig. 5:
AD1 Adsorption / AD2 Adsorption

Adsorption Dryer HRE

SWITCHOVER PROCEDURE

The switchover procedure ends the parallel phase (Figure 6).

The switchover proceeds as follows:

- disconnection of saturated adsorber (here AD1) from compressed air stream by closing the wet air inlet (here K1)
- pressure release of saturated adsorber (here AD1) to atmospheric pressure (here by valve V3)
Opening this small valve (pressure release valve), the compressed air within the saturated adsorber is led into the atmosphere via a silencer

- Opening of regeneration valve (here K3) after completion of pressure release

Now the saturated adsorber starts its regeneration with the desorption phase.

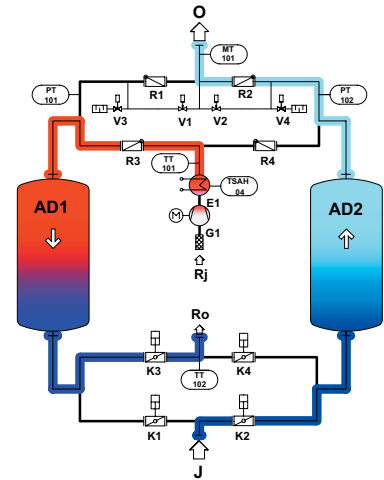

Fig. 6:
AD1 Desorption / AD2 Adsorption

OVERVIEW OF FUNCTIONAL SCHEME

		Adsorber 1	Adsorber 2
Total Cycle	Alternating Cycle	Adsorption	Pressure release
		Adsorption	Desorption
		Adsorption	Cooling
		Adsorption	Pressure built up
		Adsorption	Standby
		Adsorption	Adsorption
	Alternating Cycle	Pressure release	Adsorption
		Desorption	Adsorption
		Cooling	Adsorption
		Pressure built up	Adsorption
		Standby	Adsorption
		Adsorption	Adsorption

Switchover